



**VILLAGE OF ORLAND PARK, ILLINOIS**

**INVITATION TO BID**

**2010 Road Improvement Program**

**ISSUED**

Friday, April 2, 2010

**BID OPENING**

Monday, April 19, 2010

11:00 A.M.

**VILLAGE OF ORLAND PARK, ILLINOIS  
2010 Road Improvement Program  
INVITATION TO BID**

**TABLE OF CONTENTS**

**I. INSTRUCTIONS TO BIDDERS**

- Overview ..... 2
- Bid Specifications ..... 4
- General Provisions ..... 5
- Bid Submission Requirements ..... 9
- Evaluation of Bids/Bidders ..... 12
- Bid Submittal Checklist ..... 13

**II. REQUIRED BID SUBMISSION DOCUMENTS**

- Bidder Summary Sheet ..... 15
- Unit Price Bid Sheet ..... 16
- Business Organization ..... 19
- Certificate of Eligibility to Enter into Contracts ..... 20
- Equal Employment Opportunity ..... 21
- Certification of Compliance With the Illinois Prevailing Wage Act ..... 23
- Contractor's Certification Sexual Harassment, Tax & Substance Abuse . 24
- Apprenticeship and Training Program Certification ..... 25
- References ..... 26
- Insurance Requirements ..... 27

**III. ADDITIONAL INFORMATION**

- Sample Contract (with General Conditions) ..... 29
- Index for Supplemental Specifications & Recurring Special Provisions ... 46
- IDOT Check Sheet for Recurring Special Provisions ..... 48
- Special Provisions ..... 50
- Construction Details ..... 61
- 2010 Road Improvement Program Plans  
(Under separate cover - not attached to Invitation to Bid)

**VILLAGE OF ORLAND PARK, ILLINOIS  
2010 Road Improvement Program  
INVITATION TO BID**

**I. INSTRUCTIONS TO BIDDERS**

**OVERVIEW**

The Village of Orland Park requests Bids for the 2010 Road Improvement Program (“the Project”) in the Village of Orland Park, Illinois (“Village”). See the Plans and Specifications prepared by the Village for details on the Project (“Plans and Specifications”).

In order to be responsive, **SEALED BIDS must be** signed and received by the Village of Orland Park in the Office of the Village Clerk, 14700 South Ravinia Avenue, Orland Park, Illinois 60462, **not later than 11:00 a.m., local prevailing time on Monday, April 19, 2010.** All sealed bids must be submitted to the Village Clerk, located at the above stated address. All sealed bids submitted properly will be opened publicly and read aloud immediately following the stated submission time for the Project which described in detail consists of the following:

Street resurfacing, storm sewer, curb, sidewalk, and paving improvements

Oral, telephonic, facsimile or electronically transmitted bids shall not be considered.

The Village of Orland Park, in accordance with Title VI of the Civil Rights Act of 1964, 78 Stat. 252, 42 U.S.C. 200d-4 and Title 49; Code of Federal Regulations, Subtitle A., Part 21 (Non-discrimination in Federally-Assisted Programs of the Department of Transportation) issued pursuant to said Act, hereby notifies all bidders that it will affirmatively ensure that in regard to any Contract entered into pursuant to this invitation, minority business enterprises as further specified herein will be afforded full opportunity to submit bids in response to this invitation to bid and will not be discriminated against on the grounds of race, color, creed, sex, disability, or national origin in consideration for an award

No oral comments will be made to any Bidder as to the meaning of the Plans and Specifications or other contract documents. Requests for comments must be made in writing. Contact Rich Rittenbacher by fax at (708) 403-8798, if you have any technical questions on this project. Inquiries received in writing within five (5) or more business days prior to the bid opening will be given consideration and answers will be provided in writing to all potential bidders and will be available to the public. Bidders will not be relieved of obligations due to failure to examine or receive documents, visit the site or become familiar with conditions or facts of which the Bidder should have been aware and the Village will reject all claims related thereto.

Information (other than in the form of a written Addendum issued by the Village) from any officer, agent, or employee of the Village or any other person shall not affect the risks or obligations assumed by the bidder or relieve him from fulfilling any of the conditions and

**VILLAGE OF ORLAND PARK, ILLINOIS**  
**2010 Road Improvement Program**  
**INVITATION TO BID**

obligations set forth in the bid and other contract documents. Before the bids are opened, all modification or additions to the Plans, Specifications or General Provisions, or other bid documents will be made in the form of a written Addendum issued by the Village. The Village will send copies of any such Addendum not less than three (3) business days before bids are opened to those persons who have received bid packages and provided sufficient contact information. In the event of conflict with the original contract documents, addenda shall govern all other contract documents to the extent specified. Subsequent addenda shall govern over prior addenda only to the extent specified.

**The bidder shall be required to acknowledge receipt of the formal Addendum by signing the Addendum and including it with the bid quotation.** Failure of a bidder to include a signed formal Addendum in its bid quotation shall deem its quotation non-responsive; provided, however, that the Village may waive this requirement in its best interest.

Any references in the Plans and Specifications to manufacturer's name, trade name, or catalog number (unless otherwise specified) is intended to be descriptive but not restrictive and only to indicate articles or materials that will be satisfactory. Bids on other makes and catalogs will be considered, provided each bidder clearly states on the face of their bid exactly what is proposed to be furnished. Unless so stated in the bid, it shall be understood that the bidder intends to furnish the item specified and does not propose to furnish an "equal." The Village hereby reserves the right to approve as an equal, or to reject as not being an equal any article the bidder proposes to furnish which contains minor or major variations from specification requirements, but which may comply substantially therewith.

**VILLAGE OF ORLAND PARK, ILLINOIS  
2010 Road Improvement Program  
INVITATION TO BID**

**BID SPECIFICATIONS FOR:**

2010 Road Improvement Program

**SCOPE OF WORK:**

The Village of Orland Park, Illinois is requesting bids for street resurfacing, storm sewer, curb, sidewalk, and paving improvements at various locations within the Village of Orland Park as shown on the plans accompanying this bid.

**SPECIAL CONDITIONS:**

All construction shall conform to the latest edition of the "Standard Specifications for Water and Sewer Main Construction in Illinois," and to the latest edition of the Illinois Department of Transportation "Standard Specifications for Road and Bridge Construction." Section III contains additional specifications, which must also be adhered to, in the form of:

- Special Provisions
- Construction Details

Additionally, the contractor will submit a construction schedule prior to starting any work, and submit progress reports on July 1<sup>st</sup>, August 1<sup>st</sup>, and September 15<sup>th</sup> of 2010.

**Bid Submission:**

Please provide a unit price and extended amount for each item, and a Total for the 2010 Road Improvement Program on the Unit Price Bid Sheet located in section II

**VILLAGE OF ORLAND PARK, ILLINOIS**  
**2010 Road Improvement Program**  
**INVITATION TO BID**

**GENERAL PROVISIONS**

**Contract** – The Additional Information section includes a sample standard contract, subject to modifications, that the successful bidder will be required to enter into with the Village of Orland Park within ten (10) business days of notice of bid award (hereinafter referred to as the “Contract”).

This contract will be satisfied upon completion, inspection, acceptance, and final payment for the work performed. Certain provisions of the Contract shall survive the expiration or termination of the Contract.

**Resident Inspector** – The Director of Public Works or his designee reserves the right to make any inspections at any time.

**Period of Performance** - Actual work cannot begin until the Village issues a written Notice to Proceed to the Contractor. In order to receive said Notice, the Contractor shall submit to the Village for its approval all the necessary contracts, bonds, and insurance. Village approval of the contracts, bonds, and insurance shall be evidenced by its issuance of the signed contract by the Village and the Notice to Proceed. The Village reserves the right to terminate the relationship with the successful bidder if these documents are not submitted to and approved by the Village within ten (10) days of notice of bid award.

The work to be performed by the successful bidder shall be complete on or before October 15, 2010. Liquidated damages shall be assessed daily after October 15, 2010 if the work is not complete.

Should the Contractor neglect, refuse, or fail to complete the work under the contract by October 15, 2010, and in view of the difficulty of estimating with exactness the damages caused by such delay, the Village shall have the right to charge the Contractor for each and every calendar day that the work is not complete according to the Village’s Plans and Specifications, as liquidated damages and not a penalty. This amount shall be calculated as shown in the ***Schedule of Deductions for Each Day of Overrun in Contract Time***, per ***Article 108.09: Failure to Complete the Work on Time*** of the ***Illinois Department of Transportation Standard Specifications for Road and Bridge Construction*** in its latest edition.

**VILLAGE OF ORLAND PARK, ILLINOIS**  
**2010 Road Improvement Program**  
**INVITATION TO BID**

**Payments** – Payment terms shall be pursuant to the provisions of the Local Government Prompt Payment Act (50 ILCS 505/1 *et seq.*) after receipt by the Village of Contractor's Dated Invoice, Contractor's Sworn Statement, and Lien Waiver for the amount being requested. Invoices should include the following information:

- Name and address of contractor
- Purchase order number
- Dates of service
- Previous retainage to date
- Current invoice amount
- Invoices from subcontractors
- Lien Waivers from subcontractors
- Current retainage
- Total retainage amount including current invoice

Invoices for payment must be approved by the Director of Public Works. Ten percent (10%) of the amount due will be retained from payments for completed work. Additional amounts, determined by the Director of Public Works may be withheld, until final acceptance is given. The retained amount will be authorized for payment only after all work is accepted as complete and satisfactory by the Director of Public Works.

The Village has the right to request photocopies of cancelled checks from the Contractor to his subcontractors, manufacturers, and suppliers, etc., as well as, certified payrolls. Copies of these cancelled checks and payrolls (if requested) along with all applicable Lien Waivers shall accompany each pay request and shall be submitted for the month previous to the amount shown on the pay request minus retainage.

Upon the Village's request, invoices for progress payments must include supporting documentation such as packing slips, subcontractor's invoice and material invoices.

**Changes in the Scope of Work** - Changes in the contractual scope of work shall be preceded by a duly executed Change Order itemizing any change in the Contract sum or terms and conditions and, if required by the Village, approved by the Village Board of Trustees prior to acceptance of the Change Order.

**Assignment** – Successful bidder shall not assign the work of this Project without the prior written approval of the Village.

**Compliance with Laws** – The bidder shall at all times observe and comply with all laws, ordinances and regulations of the federal, state, local and Village governments, which may in any manner affect the preparation of bids or the performance of the Contract.

Bidder hereby agrees that it will comply with all requirements of the Illinois Human Rights Act, 775 ILCS 5/1-101 et seq., including the provision dealing with sexual harassment and that if

**VILLAGE OF ORLAND PARK, ILLINOIS**  
**2010 Road Improvement Program**  
**INVITATION TO BID**

awarded the Contract will not engage in any prohibited form of discrimination in employment as defined in that Act and will require that its subcontractors agree to the same restrictions. The contractor shall maintain, and require that its subcontractors maintain, policies of equal employment opportunity which shall prohibit discrimination against any employee or applicant for employment on the basis of race, religion, color, sex, national origin, ancestry, citizenship status, age, marital status, physical or mental disability unrelated to the individual's ability to perform the essential functions of the job, association with a person with a disability, or unfavorable discharge from military service. Contractors and all subcontractors shall comply with all requirements of the Act and of the Rules of the Illinois Department of Human Rights with regard to posting information on employees' rights under the Act. Contractors and all subcontractors shall place appropriate statements identifying their companies as equal opportunity employers in all advertisements for workers to be employed in work to be performed.

Not less than the Prevailing Rate of Wages as found by the Village of Orland Park or the Department of Labor shall be paid to laborers, workmen, and mechanics performing work under the Contract. If awarded the Contract, contractor must comply with all provisions of the Illinois Prevailing Wage Act, including, but not limited to, providing certified payroll records to the Village Clerk. Contractor and subcontractors shall be required to comply with all applicable federal laws, state laws and regulations regarding minimum wages, limit on payment to minors, minimum fair wage standards for minors, payment of wage due employees, and health and safety of employees. Contractor and subcontractor are required to pay employees all rightful salaries, medical benefits, pension and social security benefits pursuant to applicable labor agreements and federal and state statutes and to further require withholdings and deposits therefore.

As required by Village code, any contractor doing work in the Village must obtain a Contractor's license from the Village of Orland's Building Department.

**Guarantees and Warranties** - All guarantees and warranties required shall be furnished by the bidder if awarded the Contract and shall be delivered to the Finance Department before final payment on the Contract is issued.

By submitting a bid, bidder expressly warrants that materials and equipment furnished under the contract will be of good quality and new unless otherwise expressly required or permitted by the contract documents, that the work will be free from defects for one (1) year from the issuance of the final payment by the Village and deficiencies shall be corrected by the contractor under its warranty immediately upon notification from the Village.

**Alternates** - Equipment and materials are specified. Alternate equipment and or material other than those outlined within this packet will need to be specified with a cut sheet within the contractor's bid. If for any reason and at the sole discretion of the Village of Orland Park any alternate equipment and or materials are deemed to be unacceptable the entire bid maybe disregarded.



**VILLAGE OF ORLAND PARK, ILLINOIS**  
**2010 Road Improvement Program**  
**INVITATION TO BID**

**Indemnification** - The selected contractor shall indemnify and hold harmless the Village of Orland Park ("Village"), its trustees, officers, directors, agents, employees, representative and assigns, from lawsuits, actions, costs (including attorney's fees), claims or liability of any character, incurred due to the alleged negligence of the Contractor, brought because of any injuries or damages received or sustained by any person, persons or property on account of any act or omission, neglect or misconduct of said Contractor, its officers, agents and/or employees arising out of, or in performance of any of the provisions of the Contract Documents, including any claims or amounts recovered for any infringements of patent, trademark or copyright; or from any claims or amounts arising or recovered under the "Worker's Compensation Act: or any other law, ordinance, order or decree. In connection with any such claims, lawsuits, actions or liabilities, the Village, its trustees, officers, directors, agents, employees, representatives and their assigns shall have the right to defense counsel of their choice. The Contractor shall be solely liable for all costs of such defense and for all expenses, fees, judgments, settlements and all other costs arising out of such claims, lawsuits, actions or liabilities.

The Contractor shall not make any settlement or compromise of a lawsuit or claim, or fail to pursue any available avenue of appeal of any adverse judgment, without the approval of the Village and any other indemnified party. The Village or any other indemnified party, in its or their sole discretion, shall have the option of being represented by its or their own counsel. If this option is exercised, then the Contractor shall promptly reimburse the Village or other indemnified party, upon written demand, for any expenses, including but not limited to court costs, reasonable attorneys' and witnesses' fees and other expenses of litigation incurred by the Village or other indemnified party in connection therewith.

**Freedom of Information Act Compliance** - The Illinois Freedom of Information Act (FOIA) has been amended and effective January 1, 2010. This amendment adds a provision to Section 7 of the Act which applies to public records in the possession of a party with whom the Village of Orland Park has contracted. The Village of Orland Park will have only a very short period of time from receipt of a FOIA request to comply with the request, and there is a significant amount of work required to process a request including collating and reviewing the information.

The undersigned acknowledges the requirements of FOIA and agrees to comply with all requests made by the Village of Orland Park for public records (as that term is defined by Section 2(c) of FOIA) in the undersigned's possession and to provide the requested public records to the Village of Orland Park within two (2) business days of the request being made by the Village of Orland Park. The undersigned agrees to indemnify and hold harmless the Village of Orland Park from all claims, costs, penalty, losses and injuries (including but not limited to, attorney's fees, other professional fees, court costs and/or arbitration or other dispute resolution costs) arising out of or relating to its failure to provide the public records to the Village of Orland Park under this agreement.

**VILLAGE OF ORLAND PARK, ILLINOIS  
2010 Road Improvement Program  
INVITATION TO BID**

**BID SUBMISSION REQUIREMENTS**

**Bidder must submit two (2) complete, sealed, signed and attested bound copies of the bid, and one (1) complete, identical, unbound copy of the bid, and shall have provided all requested information, and submitted all appropriate forms, certificates, affidavits and addendum acknowledgements in each copy in order to be considered responsive. All copies shall contain the forms with the original signatures. All copies shall include a copy of the bid bond, with the original kept separate.**

Once submitted, no bid may be withdrawn without the Village's consent, but it may be superseded by a subsequent timely bid. Any bid received after the time and date specified for opening, or any postponement thereof, will not be considered. Bids shall be irrevocable for a period of sixty (60) calendar days after the Village opens them.

Each bidder is responsible for reading the bid documents and determining that the Plans and Specifications describe the work to be performed in sufficient detail. Failure of a bidder to do so shall not relieve the bidder of any obligation with respect to said bid. Bidders shall notify the Village of any inappropriate service, brand name, component, or equipment called for by the Village in the Plans and Specifications and shall note in its bid the adjustments made to accommodate such deficiencies in the Plans and Specifications. After bids have been opened, no bidder shall assert that there was a misunderstanding concerning the nature of the work to be done or the quantities and specifications of the equipment/materials/items to be delivered, and no such claim shall relieve a bidder from its obligation to perform. All bids must be made only on the forms provided by the Village and must be made in accordance with this Invitation to Bid and Plans and Specifications (Project manual), all of which are on file and may be obtained for examination in the Clerk's Office at the above address and are made part of this notice as though fully set forth herein.

**Bidder Summary Sheet** – Section II includes the Bidder Summary Sheet that must be completed and submitted with the bid package.

**Unit Price Bid Sheet** – Section II includes the Unit Price Bid Sheet that must be fully completed and submitted with the bid package.

**Bid Deposit** - Each bid must be accompanied by a bid deposit, as earnest money, in the form of a bid bond, a certified check or cashier's check, drawn on a responsible bank, made payable to the order of the Village of Orland Park for 10% of the total amount of the base bid price. As soon as the bid prices have been compared, the Village will return the deposit of all except the three lowest bidders.

**References** – Bidders shall provide the Village with the names and contact information of three (3) references for which they have performed similar work. The bidders grant Village permission to contact said references and ask questions regarding prior work performance.

**VILLAGE OF ORLAND PARK, ILLINOIS  
2010 Road Improvement Program  
INVITATION TO BID**

Village shall use the information gained from bidder's references to further evaluate the bidders.

**Insurance** – Contractor shall purchase and maintain, at all times during the performance of the work under this Contract, insurance coverage and endorsements, including Worker's Compensation, Automobile Liability, Comprehensive General Liability and Excess Liability, in the amounts set forth in the Village's Insurance Requirements attached in Section II. **Bidders must sign and submit with the bid, the Insurance Requirements page, as recognition of the insurance coverages and amounts (hereinafter referred to as "coverage(s)") that will be required to be in place before the commencement of any work by the successful bidder.** By signing this form, the bidder is certifying that in the event the bidder does not already have the required insurance coverages in place, that the bidder has checked with their insurance carrier and verified that the coverages and endorsements requested will be able to be obtained by the bidder within ten (10) days after the date of the Notice of Award of the Contract. The bidder has the sole responsibility of verifying that the coverages and endorsements will be available for purchase and has made any and all inquiries necessary to satisfy this requirement and fully inform themselves in regards to any additional policy premiums the successful bidder may incur as a result of obtaining said required coverage's. The bidder also represents that they have taken the insurance requirements into account and at the bidders' sole discretion, has factored this into the bid prices submitted. The successful bidder is solely and entirely responsible for the payment of policy premiums and in no event will the Village of Orland Park be obligated to incur any additional expense, nor will the Village increase the amount of the Contract above the amount bid, as a result of any expense the successful bidder may incur to satisfy the obligations required herein.

**Please submit with the bid, a current policy Specimen Certificate of Insurance showing the insurance coverages the bidder currently has in force.**

Upon award of the contract, any insurance policies providing the coverages required of the Contractor shall be specifically endorsed to identify "*The Village of Orland Park, and their respective officers, trustees, directors, employees and agents as Additional Insureds on a primary/non-contributory basis with respect to all claims arising out of operations by or on behalf of the named insured.*" If the named insureds have other applicable insurance coverage, that coverage shall be deemed to be on an excess or contingent basis. The policies shall also contain a "Waiver of Subrogation in favor of the Additional Insureds in regards to General Liability and Workers Compensation coverage's." The certificate of insurance shall also state this information on its face and endorsements will be required to be submitted if awarded the contract. Certificates of insurance must state that the insurer shall provide the Village with thirty (30) days prior written notice of any change in, or cancellation of required insurance policies. The words "endeavor to" and "but failure to do so shall impose no obligation or liability of any kind upon the insurer, its agents or representatives" must be stricken from all Certificates of Insurance submitted to the Village, but failure of the insurer to strike this reference shall not be a waiver of the obligation to provide any written notice.

**VILLAGE OF ORLAND PARK, ILLINOIS  
2010 Road Improvement Program  
INVITATION TO BID**

**Performance Bond** –When the Contract is executed with the final successful bidder, the deposits of the other remaining unsuccessful bidders will be returned or otherwise caused to be cancelled. The bid deposit of the successful bidder will be retained until Payment and Performance Bonds and Insurance Certificates have been received and approved, at which time the bid bond will be returned. A Payment and Performance Bond, in the amount of one hundred percent (100%) of the contract price, with a corporation surety satisfactory to the Village, will be required to assure performance of the Contract. Any attorney-in-fact who signs any bond must attach to each bond an effective copy of his power of attorney, the date of the bond specifically including such date within the authority conferred thereby.

Payment and Performance Bonds must be provided by a company listed in Federal Register Circular 570, latest revision, Surety Companies Acceptable on Federal Bonds, and a Financial Rating of V or better as published by Best's Key Rating Guide, latest edition. Additionally, the bonding firm must be registered to do business in Illinois by the State of Illinois Department of Insurance.

In case of failure of the bidder to timely provide the Payment and Performance Bonds and Certificate of Insurance, the Village may at its option, declare the bidder in default of the Contract, in which case the bid deposit accompanying the bid shall be forfeited to, and shall become the property of the Village. The Village may elect either to accept the next lowest responsible bid, or re-advertise for new bids and take such other actions as are provided for under the default termination provisions of the Contract.

Execution of the Contract by the Village will be contingent upon provision of the required bonds and insurance certificates. A "Notice to Proceed" will not be issued and work may not commence until required payment and performance bonds are in place.

**Bid Price** - The submitted bid price shall include all permits, insurance, bonds, goods/materials/equipment, plant facilities, work and expense necessary to perform the work in accordance with the Plans and Specifications included in this bid package. The submitted bid price shall not include any amount for sales or use taxes, or any other tax from which the Village is exempt.

The Plans and Specifications describe the standards of construction and are not intended to describe a particular manufacturer's product.

**VILLAGE OF ORLAND PARK, ILLINOIS  
2010 Road Improvement Program  
INVITATION TO BID**

**EVALUATION OF BIDS/BIDDERS**

The Village reserves the right to accept any bid, any part or parts thereof, or to reject any and all bids.

The Village reserves the right to waive minor informalities or irregularities in the bids received, to accept any bid deemed advantageous to the Village, or to reject any and all bids submitted. Conditional bids, or those which take exception to the Contract documents without prior written approval from the Village, may be considered non-responsive and may be rejected.

The Village may make such investigations as it deems necessary to determine the ability of the bidder to perform the work in conformity with the Contract documents, and the bidder shall furnish to the Village all such information and data for this purpose as the Village may request.

The Contract shall be awarded to the lowest responsive, responsible bidder. In determining the lowest responsive and responsible bid, consideration will be given to several factors, including but not limited to price, financial responsibility of the bidder, completion date, responsiveness to the specifications, and the experience of the Village and other purchasers with the bidders.

Award of the contract is subject to Village of Orland Park Board approval.

By submitting its bid, the bidder agrees to furnish, upon request from the Village, all information (including a list of subcontractors and suppliers and their prices) reasonably necessary for analysis. Furthermore, the Village may request that the bidder show, in detail, the kinds, quantities, and prices of direct material and direct labor used to develop prices/costs submitted in the bid. In addition, the Village reserves the right to request and receive information explaining the estimating process, including the judgmental factors and methods used to project from known data, and the contingencies used. The Village may require the bidder to show how it computes and applies indirect costs, and to show trend and budgetary data.

The Village may also conduct a pre-award facility survey of the bidder. This survey may include, but is not limited to, determining if the bidder has the experience, capability, necessary facilities and financial resources to complete the contract in a satisfactory manner within the required time.

The Village award will be made within sixty (60) calendar days after the date of the bid opening, or any mutually agreed extension thereof.

**VILLAGE OF ORLAND PARK, ILLINOIS  
2010 Road Improvement Program  
INVITATION TO BID**

**BID SUBMITTAL CHECKLIST**

In order to be responsive, the bidder must submit all of the following items:

- Sealed Bid Envelope - **Addressed to the Village of Orland Park, Attn: Village Clerk's Office**, 14700 S. Ravinia Ave., Orland Park, IL 60462, and labeled: **2010 Road Improvement Project - Bid**, in the lower left hand corner.
- Bid - Bidder must submit **two (2) complete, sealed, signed and attested bound copies of the bid, and one (1) complete, identical, unbound copy of the bid**, and shall have provided all requested information, and submitted all appropriate forms, certificates, affidavits and addendum acknowledgements in each copy in order to be considered responsive. All copies shall contain the forms with the original signatures (please include a photocopy of the bid bond in tall copies – original kept separate). Note: only include those required documents listed in Section II and Section III in the bid submission.
- Bid Bond/Check for 10% of the bid amount
- All forms completed from Section II:
  - Bidder Summary Sheet
  - Unit Price Bid Sheet
  - Business Organization
  - Certificate of Eligibility to Enter into Public Contracts
  - Equal Employment Opportunity
  - Certification of Compliance With the Illinois Prevailing Wage Act
  - Contractor's Certification Sexual Harassment, Tax & Substance Abuse
  - Apprenticeship and Training Program Certification
  - References
  - Insurance Requirements

## **II – REQUIRED BID SUBMISSION DOCUMENTS**

**BIDDER SUMMARY SHEET**  
**2010 Road Improvement Program**

IN WITNESS WHEREOF, the parties hereto have executed this Bid as of date shown below.

Firm Name: \_\_\_\_\_

Address: \_\_\_\_\_

City, State, Zip Code: \_\_\_\_\_

**Contact Person:** \_\_\_\_\_

FEIN #: \_\_\_\_\_

Phone: (\_\_\_\_) \_\_\_\_\_ Fax: (\_\_\_\_) \_\_\_\_\_

E-mail Address: \_\_\_\_\_

Signature of Authorized Signee: \_\_\_\_\_

Title: \_\_\_\_\_ Date: \_\_\_\_\_

**RECEIPT OF ADDENDA:** The receipt of the following addenda is hereby acknowledged:

Addendum No. \_\_\_\_\_, Dated \_\_\_\_\_

Addendum No. \_\_\_\_\_, Dated \_\_\_\_\_

**TOTAL BID PRICE:**        \$ \_\_\_\_\_

**ACCEPTANCE:**    This proposal is valid for \_\_\_\_\_ calendar days from the date of submittal.  
(NOTE: At least 60 days should be allowed for evaluation and approval.)



## UNIT PRICE BID SHEET

### 2010 Road Improvement Program

*Orland Park Street Resurfacing, Storm Sewer, Curb, Sidewalk, and Paving Improvements*

The undersigned, having become familiar with the Documents, Construction Plans, and Specifications on file in the office of the Owner as designated in the Invitation to Bid, hereby proposes to provide and furnish all of the labor, materials, necessary tools, expendable equipment and all utility and transportation services necessary to perform and complete in a workmanlike manner all of the work required for and the work described in the following schedule in connection with the construction of the 2010 Road Improvement Program- street resurfacing, storm sewer, curb, sidewalk, and paving improvements.

<u>ITEM</u>	<u>DESCRIPTION</u>	<u>QUANTITY</u>	<u>UNIT PRICE</u>	<u>AMOUNT</u>
01.	4" P.C.C. MEDIAN SURFACE	2300 S.F.	_____	_____
02.	5 FT. x 5 IN. PCC SIDEWALK	3250 S.F.	_____	_____
03.	REMOVE & REPLACE 5 IN. PCC SIDEWALK	11910 S.F.	_____	_____
04.	DETECTABLE WARNING PLATE	64 EA.	_____	_____
05.	CURB & GUTTER, M-3.12	235 L.F.	_____	_____
06.	CURB & GUTTER, B-6.12	605 L.F.	_____	_____
07.	REMOVE & REPLACE CURB & GUTTER, M3.12 CURB	9160 L.F.	_____	_____
08.	REMOVE & REPLACE CURB & GUTTER, B6.12 CURB	650 L.F.	_____	_____
09.	CONCRETE SLAB RAISING	2150 S.F.	_____	_____
10.	PNEUMATIC CURB REPAIR	2170 L.F.	_____	_____
11.	REMOVE & REPLACE 6 IN. P.C.C. DRIVEWAY PAVEMENT	1150 S.F.	_____	_____
12.	REMOVE & REPLACE 2.5 IN. ASPHALT DRIVEWAY PAVEMENT	112 S.Y.	_____	_____
13.	PAVING BRICK DRIVEWAY REPAIR	290 S.F.	_____	_____
14.	HMA IMPRINTED DRIVEWAY PAVEMENT REPAIR	10 S.Y.	_____	_____
15.	EARTH EXCAVATION	158 C.Y.	_____	_____

<u>ITEM</u>	<u>DESCRIPTION</u>	<u>QUANTITY</u>	<u>UNIT PRICE</u>	<u>AMOUNT</u>
16.	BITUMINOUS SURFACE REMOVAL, ENTIRE ROAD WIDTH (1.75" Depth)	37800 S.Y.		
17.	BITUMINOUS SURFACE REMOVAL, EDGE MILLING	28850 S.Y.		
18.	BITUMINOUS MATERIALS, PRIME COAT	22420 GAL.		
19.	BITUMINOUS MATERIALS- PRIME COAT, REFLECTIVE CRACK CONTROL	19790 GAL.		
20.	HOT IN-PLACE PAVEMENT RECYCLING	9900 S.Y.		
21.	CLASS D PATCHES, VARIOUS TYPES (PLAN)	3365 TON		
22.	CLASS D PATCHES, VARIOUS TYPES - OFF-SITE	800 TON		
23.	MIXTURE FOR CRACKS, JOINTS AND FLANGEWAYS	8 TON		
24.	PREPARATION OF BASE	140 S.Y.		
25.	AGGREGATE BASE REPAIR	170 TON		
26.	AGGREGATE BASE COURSE, TYPE B	73 TON		
27.	TRENCH BACKFILL, WASHED CA-7	677 TON		
28.	TRENCH BACKFILL, CA-6	1125 TON		
29.	LEVELING BINDER, MACHINE METHOD, N50	4040 TON		
30.	HOT-MIX ASPHALT BINDER COURSE, IL-19, N50	25 TON		
31.	HOT-MIX ASPHALT SURFACE COURSE, MIX "C", N50	10995 TON		
32.	AREA REFLECTIVE CRACK CONTROL TREATMENT, SYSTEM A- 4 OZ./S.Y.	66220 S.Y.		
33.	STRIP REFLECTIVE CRACK CONTROL TREATMENT, SYSTEM B	450 S.F.		
34.	SEEDING, SALT TOLERANT LAWN MIXTURE	7 1200 S.Y.		
35.	SODDING (& TOPSOIL)	1890 S.Y.		
36.	TOPSOIL FURNISH AND PLACE, 9"	110 S.Y.		
37.	PAVING BRICK PAVEMENT	550 S.F.		
38.	6 IN. PERFORATED PVC STORM SEWER UNDERDRAIN	10060 L.F.		

<u>ITEM</u>	<u>DESCRIPTION</u>	<u>QUANTITY</u>	<u>UNIT PRICE</u>	<u>AMOUNT</u>
39.	24 IN. INLET	45 EA.	_____	_____
40.	FRAMES & LIDS TO BE ADJUSTED (Steel Ring)	17 EA.	_____	_____
41.	ADJUST & REMORTAR STRUCTURE FRAME	44 EA.	_____	_____
42.	RECONSTRUCT MANHOLE, BLOCK	3 EA.	_____	_____
43.	RECONSTRUCT MANHOLE, CONE SECTION	2 EA.	_____	_____
44.	RECONSTRUCT MANHOLE, FLAT SLAB	2 EA.	_____	_____
45.	RE-MORTAR STRUCTURE	132 EA.	_____	_____
46.	THERMOPLASTIC PAVEMENT MARKING, LINE	3365 S.F.	_____	_____
47.	THERMOPLASTIC PAVEMENT MARKING, SYMBOL	60 S.F.	_____	_____
48.	DETECTOR LOOP	180 L.F.	_____	_____

**TOTAL AMOUNT**

**\$ \_\_\_\_\_**  
**(Enter this amount as Total Bid Price on bidder summary sheet)**

The foregoing total shall be the basis for establishing the amount of the labor and payment and performance bonds and is not to be construed as a lump sum Contract Price. The actual number of units used will determine the final cost of the project

Bidder/Contractor:

Firm Name: \_\_\_\_\_

Signed: \_\_\_\_\_

Title: \_\_\_\_\_

Dated: \_\_\_\_\_

Attest: \_\_\_\_\_

**BUSINESS ORGANIZATION:**

\_\_\_\_\_ Sole Proprietor: An individual whose signature is affixed to this bid.

\_\_\_\_\_ Partnership: Attach sheet and state full names, titles and address of all responsible principals and/or partners. Provide percent of ownership and a copy of partnership agreement.

\_\_\_\_\_ Corporation: State of incorporation: \_\_\_\_\_  
Provide a disclosure of all officers and principals by name and business address, date of incorporation and indicate if the corporation is authorized to do business in Illinois.

In submitting this bid, it is understood that the Village of Orland Park reserves the right to reject any or all bids, to accept an alternate bid, and to waive any informalities in any bid.

In compliance with your Invitation to Bid, and subject to all conditions thereof, the undersigned offers and agrees, if this bid is accepted, to furnish the services as outlined.

\_\_\_\_\_ (Corporate Seal)  
Business Name

\_\_\_\_\_ Signature \_\_\_\_\_ Print or type name

\_\_\_\_\_ Title \_\_\_\_\_ Date

**CERTIFICATION OF ELIGIBILITY  
TO ENTER INTO PUBLIC CONTRACTS**

**IMPORTANT: THIS CERTIFICATION MUST BE EXECUTED.**

I, \_\_\_\_\_, being first duly sworn certify  
and say that I am \_\_\_\_\_  
(insert "sole owner," "partner," "president," or other proper title)

of \_\_\_\_\_, the Prime Contractor submitting this proposal, and that the Prime Contractor is not barred from contracting with any unit of state or local government as a result of a violation of either Section 33E-3, or 33E-4 of the Illinois Criminal Code, or of any similar offense of "bid-rigging" or "bid-rotating" of any state or of the United States.

\_\_\_\_\_  
Signature of Person Making Certification

Subscribed and Sworn To  
Before Me This \_\_\_\_\_ Day  
of \_\_\_\_\_, 2010.

\_\_\_\_\_  
Notary Public

## EQUAL EMPLOYMENT OPPORTUNITY

**Section I.** This EQUAL EMPLOYMENT OPPORTUNITY CLAUSE is required by the Illinois Human Rights Act and the Rules and Regulations of the Illinois Department of Human Rights published at 44 Illinois Administrative Code Section 750, et seq.

**Section II.** In the event of the Contractor's noncompliance with any provision of this Equal Employment Opportunity Clause, the Illinois Human Right Act, or the Rules and Regulations for Public Contracts of the Department of Human Rights (hereinafter referred to as the Department) the Contractor may be declared non-responsible and therefore ineligible for future contracts or subcontracts with the State of Illinois or any of its political subdivisions or municipal corporations, and this agreement may be canceled or avoided in whole or in part, and such other sanctions or penalties may be imposed or remedies involved as provided by statute or regulation.

During the performance of this Agreement, the Contractor agrees:

**A.** That it will not discriminate against any employee or applicant for employment because of race, color, religion, sex, national origin or ancestry; and further that it will examine all job classifications to determine if minority persons or women are underutilized and will take appropriate affirmative action to rectify any such underutilization.

**B.** That, if it hires additional employees in order to perform this Agreement, or any portion hereof, it will determine the availability (in accordance with the Department's Rules and Regulations for Public Contracts) of minorities and women in the area(s) from which it may reasonably recruit and it will hire for each job classification for which employees are hired in such a way that minorities and women are not underutilized.

**C.** That, in all solicitations or advertisements for employees placed by it or on its behalf, it will state that all applicants will be afforded equal opportunity without discrimination because of race, color, religion, sex, marital status, national origin or ancestry, age, or physical or mental handicap unrelated to ability, or an unfavorable discharge from military service.

**D.** That it will send to each labor organization or representative of workers with which it has or is bound by a collective bargaining or other agreement or understanding, a notice advising such labor organization or representative of the Contractor's obligations under the Illinois Human Rights Act and Department's Rules and Regulations for Public Contract.

**E.** That it will submit reports as required by the Department's Rules and Regulations for Public Contracts, furnish all relevant information as may from time to time be requested by the Department or the contracting agency, and in all respects comply with the Illinois Human Rights Act and Department's Rules and Regulations for Public Contracts.

**F.** That it will permit access to all relevant books, records, accounts and work sites by personnel of the contracting agency and Department for purposes of investigation to

ascertain compliance with the Illinois Human Rights Act and Department's Rules and Regulations for Public Contracts.

**G.** That it will include verbatim or by reference the provisions of this Equal Employment Opportunity Clause in every subcontract it awards under which any portion of this Agreement obligations are undertaken or assumed, so that such provisions will be binding upon such subcontractor. In the same manner as the other provisions of this Agreement, the Contractor will be liable for compliance with applicable provisions of this clause by such subcontractors; and further it will promptly notify the contracting agency and the Department in the event any subcontractor fails or refuses to comply therewith. In addition, the Contractor will not utilize any subcontractor declared by the Illinois Human Rights Department to be ineligible for contracts or subcontracts with the State of Illinois or any of its political subdivisions or municipal corporations.

**Section III.** For the purposes of subsection G of Section II, "subcontract" means any agreement, arrangement or understanding, written or otherwise, between the Contractor and any person under which any portion of the Contractor's obligations under one or more public contracts is performed, undertaken or assumed; the term "subcontract", however, shall not include any agreement, arrangement or understanding in which the parties stand in the relationship of an employer and an employee, or between a Contractor or other organization and its customers.

**ACKNOWLEDGED AND AGREED TO:**

**BY:** \_\_\_\_\_

**ATTEST:** \_\_\_\_\_

**DATE:** \_\_\_\_\_

**CERTIFICATION OF COMPLIANCE WITH THE  
ILLINOIS PREVAILING WAGE ACT  
(820 ILCS 130/0.01, et seq.)**

It is hereby stipulated and certified to the Village of Orland Park, that the undersigned Contractor shall pay not less than the prevailing hourly rate of wages, the generally prevailing rate of hourly wages for legal holiday and overtime work, and the prevailing hourly rate for welfare and other benefits as determined by the Illinois Department of Labor and as set forth in the schedule of prevailing wages for this contract to all laborers, workers and mechanics performing work under this contract. The undersigned Contractor further stipulates and certifies that he/she/it has maintained a satisfactory record of Prevailing Wage Act compliance with no significant Prevailing Wage Act violations for the past three (3) years. In accordance with Public Act 94-0515, the Contractor will submit to the Village certified payroll records (to include for every worker employed on the project the name, address, telephone number, social security number, job classification, hourly wages paid in each pay period, number of hours worked each day and starting and ending time of work each day) on a monthly basis, along with a statement affirming that such records are true and accurate, that the wages paid to each worker are not less than the required prevailing rate and that the Contractor is aware that knowingly filing false records is a Class B Misdemeanor.

**Contractor:**

**By:** \_\_\_\_\_  
(Authorized Officer)

Subscribed and Sworn to  
before me this \_\_\_\_\_ day  
of \_\_\_\_\_, 20\_\_

\_\_\_\_\_  
Notary Public



**VILLAGE OF ORLAND PARK  
CONTRACTOR'S CERTIFICATION  
SEXUAL HARASSMENT, TAX & SUBSTANCE ABUSE**

\_\_\_\_\_, having been first duly sworn deposes and states as follows:  
(Officer or Owner of Company)

\_\_\_\_\_, having submitted a proposal for:  
(Name of Company)

\_\_\_\_\_  
(PROJECT)

to the Village of Orland Park, Illinois, hereby certifies that the undersigned Contractor:

1. has a written sexual harassment policy in place in full compliance with 775 ILCS 5/2-105(A)(4).
2. is not delinquent in the payment of any tax administered by the Illinois Department of Revenue, or if:
  - a. it is contesting its liability for the tax or the amount of tax in accordance with procedures established by the approved Revenue Act; or
  - b. it has entered into an agreement with the Department of Revenue for payment of all taxes due and is currently in compliance with that agreement.
3. is in full compliance with the Federal Highway Administration Rules on Controlled Substances and Alcohol Use and Testing, 49 CFR Parts 40 and 382 and that \_\_\_\_\_ is/are currently participating  
(Name of employee/driver or "all employee drivers")  
in a drug and alcohol testing program pursuant to the aforementioned rules.

\_\_\_ 4A. has in place a written program which meets or exceeds the program requirements of the Substance Abuse Prevention on Public Works Projects Act (Public Act 95-0635), and has provided a written copy thereof to the Village of Orland Park; or

\_\_\_ 4B. has in place a collective bargaining agreement which deals with the subject matter of the Substance Abuse Prevention on Public Works Projects Act (Public Act 95-0635).

(Check either 4A or 4B, depending upon which certification is correct.)

By: \_\_\_\_\_  
Officer or Owner of Company named above

Subscribed and sworn to  
Before me this \_\_\_\_\_  
Day of \_\_\_\_\_, 20\_\_.

\_\_\_\_\_  
Notary Public

**APPRENTICESHIP AND TRAINING PROGRAM CERTIFICATION**

I, \_\_\_\_\_, having been first duly sworn depose  
and state as follows:

I, \_\_\_\_\_, am the duly authorized  
agent for \_\_\_\_\_, which has

submitted a bid to the Village of Orland Park for

\_\_\_\_\_ and I hereby certify  
(Name of Project)

that \_\_\_\_\_  
(Name of Company)

participates in apprenticeship and training programs approved and registered with  
the United States Department of Labor Bureau of Apprenticeship and Training.

By: \_\_\_\_\_

Title: \_\_\_\_\_

Subscribed and Sworn to  
Before me this \_\_\_\_\_  
Day of \_\_\_\_\_, 20\_\_

\_\_\_\_\_  
Notary Public

**REFERENCES**

**(Please type)**

ORGANIZATION \_\_\_\_\_

ADDRESS \_\_\_\_\_

CITY, STATE, ZIP \_\_\_\_\_

PHONE NUMBER \_\_\_\_\_

CONTACT PERSON \_\_\_\_\_

DATE OF PROJECT \_\_\_\_\_

ORGANIZATION \_\_\_\_\_

ADDRESS \_\_\_\_\_

CITY, STATE, ZIP \_\_\_\_\_

PHONE NUMBER \_\_\_\_\_

CONTACT PERSON \_\_\_\_\_

DATE OF PROJECT \_\_\_\_\_

ORGANIZATION \_\_\_\_\_

ADDRESS \_\_\_\_\_

CITY, STATE, ZIP \_\_\_\_\_

PHONE NUMBER \_\_\_\_\_

CONTACT PERSON \_\_\_\_\_

DATE OF PROJECT \_\_\_\_\_

Bidder's Name: \_\_\_\_\_

Signature & Date: \_\_\_\_\_

## INSURANCE REQUIREMENTS

*Please submit a policy Specimen Certificate of Insurance showing bidder's current coverage's*

### WORKERS COMPENSATION & EMPLOYER LIABILITY

\$500,000 – Each Accident

\$500,000 – Policy Limit

\$500,000 – Each Employee

Waiver of Subrogation in favor of the Village of Orland Park

### AUTOMOBILE LIABILITY

\$1,000,000 – Combined Single Limit

Additional Insured Endorsement in favor of the Village of Orland Park

### GENERAL LIABILITY (Occurrence basis)

\$1,000,000 – Each Occurrence

\$2,000,000 – General Aggregate Limit

\$1,000,000 – Personal & Advertising Injury

\$2,000,000 – Products/Completed Operations Aggregate

Additional Insured Endorsement & Waiver of Subrogation in favor of the Village of Orland Park

### EXCESS LIABILITY (Umbrella-Follow Form Policy)

\$5,000,000 – Each Occurrence

\$5,000,000 – Aggregate

**EXCESS MUST COVER:** General Liability, Automobile Liability, Workers Compensation

Any insurance policies providing the coverages required of the Contractor shall be specifically endorsed to identify “The Village of Orland Park, and their respective officers, trustees, directors, employees and agents as Additional Insureds on a primary/non-contributory basis with respect to all claims arising out of operations by or on behalf of the named insured.” If the named insureds have other applicable insurance coverage, that coverage shall be deemed to be on an excess or contingent basis. The policies shall also contain a Waiver of Subrogation in favor of the Additional Insureds in regards to General Liability and Workers Compensation coverage's. The certificate of insurance shall also state this information on its face. Certificates of insurance must state that the insurer shall provide the Village with thirty (30) days prior written notice of any change in, or cancellation of required insurance policies. The words “endeavor to” and “, but failure to do so shall impose no obligation or liability of any kind upon the insurer, its agents or representatives” must be stricken from all Certificates of Insurance submitted to the Village. Any insurance company providing coverage must hold an A VII rating according to Best's Key Rating Guide. Permitting the contractor, or any subcontractor, to proceed with any work prior to our receipt of the foregoing certificate and endorsement however, shall not be a waiver of the contractor's obligation to provide all of the above insurance.

The bidder agrees that if they are the selected contractor, within ten days after the date of notice of the award of the contract and prior to the commencement of any work, you will furnish evidence of Insurance coverage providing for at minimum the coverages and limits described above directly to the Village of Orland Park, Denise Domalewski, Contract Administrator, 14700 S. Ravinia Avenue, Orland Park, IL 60462. Failure to provide this evidence in the time frame specified and prior to beginning of work may result in the termination of the Village's relationship with the selected bidder and the bid will be awarded to the next lowest bidder or result in creation of a new bid.

ACCEPTED & AGREED THIS \_\_\_\_ DAY OF \_\_\_\_\_, 20\_\_

\_\_\_\_\_  
Signature

\_\_\_\_\_  
Authorized to execute agreements for:

\_\_\_\_\_  
Printed Name & Title

\_\_\_\_\_  
Name of Company

## **III – ADDITIONAL INFORMATION**

**VILLAGE OF ORLAND PARK**  
**(Contract for Small Construction or Installation Project)**

This Contract is made this \_\_\_\_ day of \_\_\_\_\_, 2010 by and between the Village of Orland Park (hereinafter referred to as the “VILLAGE”) and \_\_\_\_\_ (hereinafter referred to as the “CONTRACTOR”).

**WITNESSETH**

In consideration of the promises and covenants made herein by the VILLAGE and the CONTRACTOR (hereinafter referred to collectively as the “PARTIES”), the PARTIES agree as follows:

**SECTION 1: THE CONTRACT DOCUMENTS:** This Contract shall include the following documents (hereinafter referred to as the “CONTRACT DOCUMENTS”) however this Contract takes precedence and controls over any contrary provision in any of the CONTRACT DOCUMENTS. The Contract, including the CONTRACT DOCUMENTS, expresses the entire agreement between the PARTIES and where it modifies, adds to or deletes provisions in other CONTRACT DOCUMENTS, the Contract’s provisions shall prevail. Provisions in the CONTRACT DOCUMENTS unmodified by this Contract shall be in full force and effect in their unaltered condition.

The Contract

The Terms and General Conditions pertaining to the Contract

The VILLAGE’S Project Manual for the Work as described in Section 2 hereunder

- The Invitation to Bid
- The Instructions to the Bidders

The Bid Proposal as it is responsive to the VILLAGE’s bid requirements

All Certifications required by the VILLAGE

Certificates of Insurance

Performance and Payment Bonds required by the VILLAGE

**SECTION 2: SCOPE OF THE WORK AND PAYMENT:** The CONTRACTOR agrees to provide labor, equipment and materials necessary to perform the following:

---

---

---

---

(hereinafter referred to as the “WORK”) as described in the VILLAGE’S Project Manual (Bid Documents) and the VILLAGE agrees to pay the CONTRACTOR pursuant to the provisions of

the Local Government Prompt Payment Act (50 ILCS 505/1 *et seq.*) the following amounts for the WORK:

<u>ITEM</u>	<u>DESCRIPTION</u>	<u>QUANTITY</u>	<u>UNIT PRICE</u>	<u>AMOUNT</u>
01.	4" P.C.C. MEDIAN SURFACE	2300 S.F.	_____	_____
02.	5 FT. x 5 IN. PCC SIDEWALK	3250 S.F.	_____	_____
03.	REMOVE & REPLACE 5 IN. PCC SIDEWALK	11910 S.F.	_____	_____
04.	DETECTABLE WARNING PLATE	64 EA.	_____	_____
05.	CURB & GUTTER, M-3.12	235 L.F.	_____	_____
06.	CURB & GUTTER, B-6.12	605 L.F.	_____	_____
07.	REMOVE & REPLACE CURB & GUTTER, M3.12 CURB	9160 L.F.	_____	_____
08.	REMOVE & REPLACE CURB & GUTTER, B6.12 CURB	650 L.F.	_____	_____
09.	CONCRETE SLAB RAISING	2150 S.F.	_____	_____
10.	PNEUMATIC CURB REPAIR	2170 L.F.	_____	_____
11.	REMOVE & REPLACE 6 IN. P.C.C. DRIVEWAY PAVEMENT	1150 S.F.	_____	_____
12.	REMOVE & REPLACE 2.5 IN. ASPHALT DRIVEWAY PAVEMENT	112 S.Y.	_____	_____
13.	PAVING BRICK DRIVEWAY REPAIR	290 S.F.	_____	_____
14.	HMA IMPRINTED DRIVEWAY PAVEMENT REPAIR	10 S.Y.	_____	_____
15.	EARTH EXCAVATION	158 C.Y.	_____	_____
16.	BITUMINOUS SURFACE REMOVAL, ENTIRE ROAD WIDTH (1.75" Depth)	37800 S.Y.	_____	_____
17.	BITUMINOUS SURFACE REMOVAL, EDGE MILLING	28850 S.Y.	_____	_____
18.	BITUMINOUS MATERIALS, PRIME COAT	22420 GAL.	_____	_____
19.	BITUMINOUS MATERIALS- PRIME COAT, REFLECTIVE CRACK CONTROL	19790 GAL.	_____	_____

<u>ITEM</u>	<u>DESCRIPTION</u>	<u>QUANTITY</u>	<u>UNIT PRICE</u>	<u>AMOUNT</u>
20.	HOT IN-PLACE PAVEMENT RECYCLING	9900 S.Y.	_____	_____
21.	CLASS D PATCHES, VARIOUS TYPES (PLAN)	3365 TON	_____	_____
22.	CLASS D PATCHES, VARIOUS TYPES – OFF-SITE	800 TON	_____	_____
23.	MIXTURE FOR CRACKS, JOINTS AND FLANGEWAYS	8 TON	_____	_____
24.	PREPARATION OF BASE	140 S.Y.	_____	_____
25.	AGGREGATE BASE REPAIR	170 TON	_____	_____
26.	AGGREGATE BASE COURSE, TYPE B	73 TON	_____	_____
27.	TRENCH BACKFILL, WASHED CA-7	677 TON	_____	_____
28.	TRENCH BACKFILL, CA-6	1125 TON	_____	_____
29.	LEVELING BINDER, MACHINE METHOD, N50	4040 TON	_____	_____
30.	HOT-MIX ASPHALT BINDER COURSE, IL-19, N50	25 TON	_____	_____
31.	HOT-MIX ASPHALT SURFACE COURSE, MIX "C", N50	10995 TON	_____	_____
32.	AREA REFLECTIVE CRACK CONTROL TREATMENT, SYSTEM A- 4 OZ./S.Y.	66220 S.Y.	_____	_____
33.	STRIP REFLECTIVE CRACK CONTROL TREATMENT, SYSTEM B	450 S.F.	_____	_____
34.	SEEDING, SALT TOLERANT LAWN MIXTURE	7 1200 S.Y.	_____	_____
35.	SODDING (& TOPSOIL)	1890 S.Y.	_____	_____
36.	TOPSOIL FURNISH AND PLACE, 9"	110 S.Y.	_____	_____
37.	PAVING BRICK PAVEMENT	550 S.F.	_____	_____
38.	6 IN. PERFORATED PVC STORM SEWER UNDERDRAIN	10060 L.F.	_____	_____
39.	24 IN. INLET	45 EA.	_____	_____
40.	FRAMES & LIDS TO BE ADJUSTED (Steel Ring)	17 EA.	_____	_____
41.	ADJUST & REMORTAR STRUCTURE FRAME	44 EA.	_____	_____



<u>ITEM</u>	<u>DESCRIPTION</u>	<u>QUANTITY</u>	<u>UNIT PRICE</u>	<u>AMOUNT</u>
42.	RECONSTRUCT MANHOLE, BLOCK	3 EA.	_____	_____
43.	RECONSTRUCT MANHOLE, CONE SECTION	2 EA.	_____	_____
44.	RECONSTRUCT MANHOLE, FLAT SLAB	2 EA.	_____	_____
45.	RE-MORTAR STRUCTURE	132 EA.	_____	_____
46.	THERMOPLASTIC PAVEMENT MARKING, LINE	3365 S.F.	_____	_____
47.	THERMOPLASTIC PAVEMENT MARKING, SYMBOL	60 S.F.	_____	_____
48.	DETECTOR LOOP	180 L.F.	_____	_____
<b>TOTAL AMOUNT</b>			<b>\$</b> _____	_____

Alternates chosen:

\_\_\_\_\_  
 \_\_\_\_\_

TOTAL: \_\_\_\_\_ No/100 (\$ \_\_\_\_\_) Dollars  
 (hereinafter referred to as the "CONTRACT SUM.") The CONTRACT SUM shall not be increased without the express written consent of the VILLAGE.

**SECTION 3: ASSIGNMENT:** CONTRACTOR shall not assign the duties and obligations involved in the performance of the WORK except to the list of Subcontractors approved by the Village, which approval shall not be unreasonably withheld.

**SECTION 4: TERM OF THE CONTRACT:** The CONTRACTOR shall commence the WORK of this Contract upon receipt of a Notice to Proceed and shall complete performance of the WORK of this Contract by \_\_\_\_\_, (hereinafter referred to as the "CONTRACT TIME.") Failure to meet the CONTRACT TIME shall be considered an occasion of default under the CONTRACT DOCUMENTS. The CONTRACT TIME shall not be increased without the express written consent of the VILLAGE. Final payment shall be made by the VILLAGE upon inspection of the WORK, completion of any punch list items and after receipt of final release and waiver of liens in accordance with the requirements of the CONTRACT DOCUMENTS. This Contract may be terminated by the VILLAGE for convenience or by either of the PARTIES for default in the performance of the duties of the PARTIES as described in the CONTRACT DOCUMENTS upon thirty (30) day's written notice provided as required herein.

**SECTION 5: INDEMNIFICATION AND INSURANCE:** The CONTRACTOR shall

indemnify and hold harmless the VILLAGE, its trustees, officers, directors, agents, employees and representatives and assigns, from lawsuits, actions, costs (including attorneys' fees), claims or liability of any character, incurred due to the alleged negligence of the CONTRACTOR, brought because of any injuries or damages received or sustained by any person, persons or property on account of any act or omission, neglect or misconduct of said CONTRACTOR, its officers, agents and/or employees arising out of, or in performance of any of the provisions of the CONTRACT DOCUMENTS, including any claims or amounts recovered for any infringements of patent, trademark or copyright; or from any claims or amounts arising or recovered under the "Worker's Compensation Act" or any other law, ordinance, order or decree. In connection with any such claims, lawsuits, actions or liabilities, the VILLAGE, its trustees, officers, directors, agents, employees, representatives and their assigns shall have the right to defense counsel of their choice. The CONTRACTOR shall be solely liable for all costs of such defense and for all expenses, fees, judgments, settlements and all other costs arising out of such claims, lawsuits, actions or liabilities.

The Contractor shall not make any settlement or compromise of a lawsuit or claim, or fail to pursue any available avenue of appeal of any adverse judgment, without the approval of the Village and any other indemnified party. The Village or any other indemnified party, in its or their sole discretion, shall have the option of being represented by its or their own counsel. If this option is exercised, then the Contractor shall promptly reimburse the Village or other indemnified party, upon written demand, for any expenses, including but not limited to court costs, reasonable attorneys' and witnesses' fees and other expenses of litigation incurred by the Village or other indemnified party in connection therewith.

The indemnification obligation under this paragraph shall not be limited in any way by any limitations on the amount or type of damages, compensation or benefits payable by or for the benefit of Subcontractor or any indemnities under any Worker's Compensation Act, Occupational Disease Act, Disability Benefits Act, or any other employee benefits act. The Subcontractor further agrees to waive any and all liability limitations based upon the Worker's Compensation Act court interpretations or otherwise.

Execution of this Contract by the VILLAGE is contingent upon receipt of Insurance Certificates provided by the CONTRACTOR in compliance with the CONTRACT DOCUMENTS.

**SECTION 6: COMPLIANCE WITH LAWS:** CONTRACTOR agrees to comply with all federal, state and local laws, ordinances, statutes, rules and regulations including but not limited to all applicable provisions of the Illinois Human Rights Act (775 ILCS 5/1-101 *et seq.*) and the Illinois Prevailing Wage Act (820 ILCS 130/1 *et seq.*)

**SECTION 7: FREEDOM OF INFORMATION ACT COMPLIANCE:** The Illinois Freedom of Information Act (FOIA) has been amended and effective January 1, 2010. This amendment adds a new provision to Section 7 of the Act which applies to public records in the possession of a party with whom the Village of Orland Park has contracted. The Village of Orland Park will have only a very short period of time from receipt of a FOIA request to comply with the

request, and there is a significant amount of work required to process a request including collating and reviewing the information.

The undersigned acknowledges the requirements of FOIA and agrees to comply with all requests made by the Village of Orland Park for public records (as that term is defined by Section 2(c) of FOIA) in the undersigned's possession and to provide the requested public records to the Village of Orland Park within two (2) business days of the request being made by the Village of Orland Park. The undersigned agrees to indemnify and hold harmless the Village of Orland Park from all claims, costs, penalty, losses and injuries (including but not limited to, attorney's fees, other professional fees, court costs and/or arbitration or other dispute resolution costs) arising out of or relating to its failure to provide the public records to the Village of Orland Park under this agreement.

**SECTION 8: NOTICE:** Where notice is required by the CONTRACT DOCUMENTS, it shall be considered received if it is 1) delivered in person, 2) sent by registered United States mail, return receipt requested, 3) delivered by messenger or mail service with a signed receipt, 4) sent by facsimile with an acknowledgment of receipt, or 4) by e-mail with an acknowledgment of receipt only if the PARTIES agree separately to use e-mail for providing notice. Notice shall be sent to the following:

To the VILLAGE:

Denise Domalewski, Contract Administrator  
Village of Orland Park  
14700 South Ravinia Avenue  
Orland Park, Illinois 60462  
Telephone: 708-403-6173  
Facsimile: 708-403-9212  
e-mail: [ddomalewski@orland-park.il.us](mailto:ddomalewski@orland-park.il.us)

To the CONTRACTOR:

Telephone:  
Facsimile:  
e-mail:

or to such other persons or to such other addresses as may be provided by one party to the other party under the requirements of this Section.

**SECTION 9: LAW AND VENUE:** The law of the State of Illinois shall apply to this Agreement and venue for legal disputes shall be Cook County, Illinois.

**SECTION 10: MODIFICATION:** This Contract may be modified only by a written amendment signed by both PARTIES.

**SECTION 11: COUNTERPARTS:** This Contract may be executed in two (2) or more counterparts, each of which taken together, shall constitute one and the same instrument.

This Contract shall become effective on the date first shown herein and upon execution by duly authorized agents of the PARTIES.

FOR: THE VILLAGE

FOR: THE CONTRACTOR

By: \_\_\_\_\_

By: \_\_\_\_\_

Print name: \_\_\_\_\_

Print name: \_\_\_\_\_

Its: Village Manager

Its: \_\_\_\_\_

Date: \_\_\_\_\_

Date: \_\_\_\_\_

SAMPLE

**VILLAGE OF ORLAND PARK  
CONSTRUCTION CONTRACT**

Terms and General Conditions for the CONTRACT between the Village of Orland Park (the “VILLAGE”) and \_\_\_\_\_ (the “CONTRACTOR”) for \_\_\_\_\_ (the “WORK”) dated \_\_\_\_\_ (the “CONTRACT”).

**ARTICLE 1: DUTIES OF THE PARTIES**

**1.1 VILLAGE’S RIGHTS AND DUTIES**

- 1.1.1 Upon request of CONTRACTOR the VILLAGE shall furnish in a timely and agreed upon schedule and manner, information relevant to the project or project site as requested by the CONTRACTOR and deemed by the CONTRACTOR and the Village to be necessary for the performance of the WORK of the CONTRACT.
- 1.1.2 The VILLAGE shall furnish access to its buildings and the site of the WORK, as is necessary and in the best interests of the VILLAGE, for the performance of the WORK and shall provide, at its own expense as needed, temporary or permanent easements, zoning and other remedy as may be requested by the CONTRACTOR to remove or reduce restrictions or limitations that negatively affect the CONTRACTOR’S ability to perform the WORK as outlined in the bidding documents and the CONTRACT.
- 1.1.3 The VILLAGE shall have the right to immediately stop the WORK by providing written notice to the CONTRACTOR should the CONTRACTOR fail to correct WORK not in accordance with the CONTRACT Documents which stoppage will remain in effect until the WORK is corrected without giving rise to any duty on the part of the VILLAGE to stop the WORK for the benefit of the CONTRACTOR or any other entity.
- 1.1.4 The VILLAGE may, at the CONTRACTOR’S expense, correct deficiencies in the WORK to make it conform to the CONTRACT.
- 1.1.5 If the CONTRACTOR does not correct or cure a default, with reasonable promptness after receiving a written notice from the VILLAGE, the VILLAGE may, at its option, correct the default and deduct the VILLAGE’s cost of the correction or cure from the amounts owed to the CONTRACTOR.

## 1.2 CONTRACTOR'S RIGHTS AND DUTIES

- 1.2.1 The CONTRACTOR shall perform the WORK in accordance with the CONTRACT documents.
- 1.2.2 The CONTRACTOR shall examine existing conditions and take field measurements to facilitate the performance of the WORK throughout the duration of the CONTRACT and shall report to the VILLAGE any errors, inconsistencies or omissions discovered during the performance of the CONTRACT.
- 1.2.3 CONTRACTOR shall pay for all material, labor and incidental costs necessary for the completion of the WORK.
- 1.2.4 CONTRACTOR warrants that the WORK performed/provided shall be fully compliant with the plans, specifications and bid documents for the WORK. The CONTRACTOR warrants that the WORK shall be free from defects for one (1) year after the final acceptance of the WORK by the VILLAGE, or the length of time guaranteed under the warranty provided by the manufacturer for materials used in the WORK, whichever is greater. Where there are defects and/or deficiencies, following notice of said defects or deficiencies provided to the CONTRACTOR by the VILLAGE, the CONTRACTOR agrees to promptly correct them to the VILLAGE's satisfaction. All manufacturers' guarantees and warranties shall be delivered without variance to the VILLAGE prior to final acceptance.
- 1.2.5 The CONTRACTOR shall perform the work per the terms of the approved schedule and complete the WORK within the terms and time limits of the CONTRACT.
- 1.2.6 The CONTRACTOR shall obtain and pay for all required permits, licenses, fees, inspections and certifications required of or by the WORK.
- 1.2.7 CONTRACTOR shall comply with all local, state and federal statutes, ordinances, codes, rules, and regulations governing the performance of the CONTRACTOR for the completion of the WORK, including but not limited to all of the applicable provisions of the Illinois Prevailing Wage Act (820 ILCS 130/1 *et seq.*) and the Illinois Human Rights Act (775 ILCS 5/1-01 *et seq.*) The CONTRACTOR shall obtain and preserve per the terms of the Document Retention Laws of the State of Illinois, certified payroll records for all work performed to complete the WORK, including that work performed by all those contractors subordinate to the CONTRACTOR or Subcontractor. Neither the CONTRACTOR nor its Subcontractors shall tolerate or engage in any prohibited form of discrimination in employment

as defined in the Illinois Human Rights Act. The CONTRACTOR shall maintain, and require that its Subcontractors maintain, policies of equal employment opportunity which shall prohibit discrimination against any employee or applicant for employment on the basis of race, religion, color, sex, national origin, ancestry, citizenship status, age, marital status, physical or mental disability unrelated to the individual's ability to perform the essential functions of the job, association with a person with a disability, or unfavorable discharge from military service. Contractors and all Subcontractors shall comply with all requirements of the Act including maintaining a sexual harassment policy and of the Rules of the Illinois Department of Human Rights with regard to posting information on employees' rights under the Act. Contractors and all Subcontractors shall place appropriate statements identifying their companies as equal opportunity employers in all advertisements for work to be performed under the CONTRACT.

- 1.2.8 CONTRACTOR will not be relieved of any obligation to the VILLAGE under the CONTRACT due to failure to examine or receive documents, visit or become familiar with conditions or from facts of which CONTRACTOR should have been aware and VILLAGE, as existing law may allow, shall reject all claims related thereto.

## **ARTICLE 2: CONTRACT DOCUMENTS**

2.1 The CONTRACT consists of the following documents and items:

- .1 Agreement between the parties
- .2 General Conditions to the Agreement
- .3 Special Conditions to the Agreement, if any
- .4 The Project Manual dated \_\_\_\_\_ which includes
  - Instructions to the Bidders
  - Invitation to Bid
  - Specifications and Drawings, if any
- .5 Accepted Bid Proposal as it conforms to the bid requirements
- .6 Addenda, if any
- .7 Required Certificates of Insurance
- .8 Required Certifications and documents as may be required by other project funding agencies
- .9 Performance and Payment Bonds
- .10 Certification of Eligibility to Enter into Public Contracts
- .11 All Certifications required by the VILLAGE

## **ARTICLE 3: PAYMENTS AND COMPLETION**

3.1 The VILLAGE requires for each Request for Payment, a properly completed

Contractor's Affidavit setting out, under oath, the name, address and amount due or to become due, of each subcontractor, vendor, supplier or other appropriate party included in that payment. For every party listed the CONTRACTOR shall also provide a full or partial waiver of lien, as appropriate, before a payment will be made to the CONTRACTOR. The CONTRACTOR's partial or final waiver of lien must be included. Payments shall not be made by the VILLAGE without such lien waivers and contractors' sworn statements unless they are conditioned upon receipt of such waivers and statements.

3.2 No certificate shall be issued in favor of the CONTRACTOR and no payment will be made by the VILLAGE for material not installed or built into the WORK without written authorization from the VILLAGE.

3.3 Upon satisfaction of the terms and conditions of the CONTRACT, the CONTRACTOR agrees to provide the VILLAGE with a full and final release and waiver of all liens covering all of the WORK performed under the CONTRACT prior to issuance of final payment. Said final waiver of lien shall identify and state that all Subcontractors and material suppliers have been paid in full and there are no contract balances outstanding and owed to any Subcontractor or material supplier.

3.4 All payments shall be made to CONTRACTOR by VILLAGE pursuant to the provisions of the Local Government Prompt Payment Act (50 ILCS 505/1 *et seq.*)

#### **ARTICLE 4: TAXES**

4.1 The VILLAGE is a public body and is exempt from excise, sales and use taxes and will furnish CONTRACTOR with exemption numbers as required. This shall also apply to Subcontractors, and subcontractors of the Subcontractor. No Requests for Payments associated with the WORK may include any such taxes.

#### **ARTICLE 5: INSPECTION OF MATERIALS**

5.1 The VILLAGE shall have a right to inspect any materials, equipment or processes used during the performance of this CONTRACT. The CONTRACTOR shall be responsible for the Quality Assurance / Quality Control standards for all materials, equipment, components or completed WORK finished under this CONTRACT, including through the expiration of the warranty period. Materials, equipment, components or completed WORK not complying therewith may be rejected by the VILLAGE and shall be removed and replaced by the CONTRACTOR to the satisfaction of the VILLAGE, at no cost to the VILLAGE within the agreed-upon time period. All material replaced shall be fully warranted as new material

#### **ARTICLE 6: ASSIGNMENT**

6.1 The CONTRACTOR's duties and obligations under the CONTRACT shall not be assigned without the express written consent of the VILLAGE.



6.2 WORK not performed by the CONTRACTOR with its own forces shall be performed by Subcontractors or Sub-subcontractors. The CONTRACTOR shall be responsible for management of the Subcontractors in the performance of their work.

6.3 The CONTRACTOR shall not contract with anyone for performance of the WORK hereunder to whom the VILLAGE has a reasonable objection.

6.4 The CONTRACTOR shall prepare all Subcontracts and shall have full discretion to negotiate their terms, subject to the VILLAGE's reasonable requirements or objections as to form and content.

6.5 By appropriate agreement, written where legally required for validity, the CONTRACTOR shall require each Subcontractor, to the extent of the WORK to be performed by the Subcontractor, to be bound to the CONTRACTOR by terms of the CONTRACT, and to assume toward the CONTRACTOR all the obligations and responsibilities, including the responsibility for safety of the Subcontractor's work, which the CONTRACTOR, by these documents, assumes toward the VILLAGE. Each subcontract agreement shall preserve and protect the rights of the VILLAGE under the CONTRACT documents with respect to the work to be performed by the Subcontractor so that subcontracting thereof will not prejudice such rights, and shall allow to the Subcontractor, unless specifically provided otherwise in the subcontract agreement, the benefit of all rights, remedies and redress against the CONTRACTOR that the CONTRACTOR, by the CONTRACT, has against the VILLAGE. Where appropriate, the CONTRACTOR shall require each Subcontractor to enter into similar agreements with Sub-subcontractors. The CONTRACTOR shall make available to each proposed Subcontractor, prior to the execution of the subcontract agreement, copies of the contract to which the Subcontractor will be bound, and, upon written request of the Subcontractor, identify to the Subcontractor terms and conditions of the proposed subcontract agreement which may be at variance with the CONTRACT documents. Subcontractors will similarly make copies of applicable portions of such documents available to their respective proposed Sub-subcontractors.

## **ARTICLE 7: GUARANTEES AND WARRANTIES**

7.1 All guarantees and warranties required shall be furnished by the CONTRACTOR and shall be delivered to the VILLAGE before the final payment or payment retention will be paid to the CONTRACTOR.

7.2 The CONTRACTOR shall supply the VILLAGE with "as-built" plans bearing the signature and seal or stamp, of an Illinois-licensed Professional Engineer prior to the VILLAGE making the final payment.

## **ARTICLE 8: DEFAULT**

8.1 If the CONTRACTOR fails to begin the WORK under this CONTRACT within the time specified, or fails to perform the WORK in accordance with the terms of the approved

schedule or performs the WORK in a manner unacceptable to the VILLAGE, or neglects or refuses to remove materials or perform anew such WORK as has been rejected by the VILLAGE, or if the CONTRACTOR shall become insolvent or be declared bankrupt, or shall make an assignment for the benefit of creditors, or from any other cause whatsoever shall fail to carry on the WORK in a manner required by the CONTRACT, the VILLAGE shall give notice as hereinafter provided to the CONTRACTOR and its surety in writing specifying such failure, delay, neglect, refusal or default, and if the CONTRACTOR, within a period of ten (10) calendar days after the giving of such notice, shall not proceed in accordance therewith, then the VILLAGE shall have full power and authority to declare this CONTRACT and the CONTRACTOR in default, and to forfeit the rights of the CONTRACTOR in this CONTRACT.

8.2 Upon declaration of CONTRACTOR's default, the VILLAGE may, at its option, call upon the surety to complete the WORK in accordance with the terms of this CONTRACT or may take over the WORK, including any materials on the WORK site as may be suitable and acceptable to the VILLAGE and may complete the WORK by its own forces or on its own account, or may enter into a new contract or contracts for the completion of the WORK, or may use such other methods as shall be required for the completion of the WORK in an acceptable manner as the VILLAGE may in its discretion determine.

8.3 All costs and charges incurred by the VILLAGE, together with the cost of completing the WORK shall be deducted from any moneys due or which may become due on this to the CONTRACTOR under this CONTRACT. Following any payment due and received by the VILLAGE from the CONTRACTOR's surety following default, if the expense so incurred by the VILLAGE is less than the sum paid to the Village by the surety under this CONTRACT for work remaining, the surety shall be entitled to receive the excess difference paid to the VILLAGE. When such CONTRACTOR default costs incurred by the VILLAGE exceeds the sum paid to the VILLAGE for the work remaining under the CONTRACT, the CONTRACTOR and the surety shall be liable and shall pay to the VILLAGE the full cost of such additional expenses.

## **ARTICLE 9: DISPUTES AND VENUE**

9.1 Disputes between the VILLAGE and the CONTRACTOR shall be handled according to the terms of the CONTRACT (including all subsequent approved Change Orders) and applicable Law, with the final decision regarding disputes resting with the Village Manager or his or her designee. All disputes concerning a question of fact under the CONTRACT shall be expressed in writing by the parties and, if within seven (7) days after receipt of such notice the parties have not disposed of the dispute by agreement, the dispute, as it was expressed in writing by the parties, shall be subject to mediation under terms agreed to by the parties. Pending final decision of a dispute hereunder, the parties shall proceed diligently with the performance of the CONTRACT.

9.2 Any legal action taken by either party shall be decided based upon and governed by the laws of the State of Illinois and venue for such disputes shall be Cook County, Illinois.

## **ARTICLE 10: CONTRACT TIME**

10.1 Time is of the essence with respect to all performance time schedules and timely completion of the WORK under the CONTRACT. VILLAGE shall not grant, and CONTRACTOR shall not seek damages for delays. However, VILLAGE shall review a CONTRACTOR's request for additional time, and may at VILLAGE's option and as conditions warrant, grant an increase in the CONTRACT time for delays beyond CONTRACTOR's control and not caused by CONTRACTOR, its Subcontractors or others for whose actions CONTRACTOR is liable.

## **ARTICLE 11: INSURANCE AND INDEMNIFICATION**

### **11.1 Insurance Requirements**

11.1.1 The successful bidder shall, within ten (10) business days of said receipt of notice of award of the CONTRACT, furnish to the VILLAGE a certificate of insurance showing the VILLAGE, its trustees, officers, directors, agents, employees, representatives and assigns as additional insureds to the General Liability and Automobile Liability policies by appropriate endorsement. Such coverages shall be placed with a provider acceptable to the VILLAGE, which is licensed to do business in the State of Illinois, and that maintains a minimum A. M. Best rating of A VII. The insurance coverages afforded under the CONTRACTOR's General Liability insurance policies shall be primary and non-contributory to any insurance carried independently by the Indemnitees. A Waiver of Subrogation in favor of the Additional Insureds shall apply to General liability and Worker's Compensation. Certificates of insurance must state that the insurer shall provide the VILLAGE with thirty (30) days prior written notice of any change in, or cancellation of required insurance policies. All required insurance shall be maintained by the CONTRACTOR in full force and effect during the life of the CONTRACT, and until such time as all WORK has been approved and accepted by the VILLAGE. This provision constitutes the VILLAGE's continuing demand for such certificates and endorsement(s) or true and correct copies thereof and the obligation to provide such insurance coverage shall be in full force and effect during the life of the CONTRACT. Failure of the VILLAGE to request such certificates and endorsements shall not relieve the CONTRACTOR of these obligations to provide insurance.

The amounts and types of insurance required are defined in Exhibit A, a copy of which is attached hereto and made a part hereof.

11.1.2 CONTRACTOR shall cause each Subcontractor to maintain insurance of the type specified in Exhibit A. Prior to CONTRACT acceptance, and at any time when requested by the VILLAGE, CONTRACTOR shall furnish copies of certificates

of insurance evidencing coverage for each Subcontractor and Sub-subcontractor.

## 11.2 Indemnification

11.2.1 The CONTRACTOR shall indemnify and hold harmless the VILLAGE, its trustees, officers, directors, agents, employees and representatives and assigns, from lawsuits, actions, costs (including attorneys' fees), claims or liability of any character, incurred due to the alleged negligence of the CONTRACTOR, brought because of any injuries or damages received or sustained by any person, persons or property on account of any act or omission, neglect or misconduct of said CONTRACTOR, its officers, agents and/or employees arising out of, or in performance of any of the provisions of the CONTRACT DOCUMENTS, including any claims or amounts recovered for any infringements of patent, trademark or copyright; or from any claims or amounts arising or recovered under the "Worker's Compensation Act" or any other law, ordinance, order or decree. In connection with any such claims, lawsuits, actions or liabilities, the VILLAGE, its trustees, officers, directors, agents, employees, representatives and their assigns shall have the right to defense counsel of their choice. The CONTRACTOR shall be solely liable for all costs of such defense and for all expenses, fees, judgments, settlements and all other costs arising out of such claims, lawsuits, actions or liabilities.

11.2.2 The CONTRACTOR shall not make any settlement or compromise of a lawsuit or claim, or fail to pursue any available avenue of appeal of any adverse judgment, without the approval of the VILLAGE and any other indemnified party. The VILLAGE or any other indemnified party, in its or their sole discretion, shall have the option of being represented by its or their own counsel. If this option is exercised, then the CONTRACTOR shall promptly reimburse the VILLAGE or other indemnified party, upon written demand, for any expenses, including but not limited to court costs, reasonable attorneys' and witnesses' fees and other expenses of litigation incurred by the VILLAGE or other indemnified party in connection therewith.

## **ARTICLE 12: PERFORMANCE AND PAYMENT BONDS**

12.1 The CONTRACTOR shall furnish Performance and Payment Bonds acceptable to the VILLAGE in the full amount of the CONTRACT. Bonds shall be from a surety licensed to do business in Illinois and said surety shall have a minimum A.M. Best rating of A-V. Each Bond shall require a time period during which the Bond can be called limited only to the extent required by Illinois law.

## **ARTICLE 13: EXECUTION OF CONTRACT**

13.1 Execution of the CONTRACT between VILLAGE and CONTRACTOR is contingent upon receipt of required Certificates of Insurance, required signed certifications and required

Performance and Payment Bonds.

#### **ARTICLE 14: CHANGES IN THE WORK**

14.1 All changes in the WORK must be requested by CONTRACTOR and approved by the VILLAGE via an Authorization to Proceed document bearing the signature of the Project Principle for VILLAGE. Any change order or series of change orders that increase or decrease the CONTRACT value by \$10,000 or more, or that increases or decreases the CONTRACT duration beyond the approved project schedule must be accompanied by a written request from CONTRACTOR justifying the additional cost or change in schedule. Within an agreed upon period of time, VILLAGE will provide a response to CONTRACTOR's Change Order or Time request by providing a determination signed by the VILLAGE or its designee finding that the change requested was not reasonably foreseeable at the time the CONTRACT was signed, the change is germane to the CONTRACT or the change is in the best interest of VILLAGE. Any change increasing the original CONTRACT value by fifty percent (50%) or more must be re-bid by VILLAGE as required by law.

#### **ARTICLE 15: TERMINATION**

15.1 VILLAGE may, at any time, terminate the CONTRACT for the VILLAGE's convenience and without cause upon written notice to the CONTRACTOR and payment for all WORK directed to be performed prior to the effective date of termination along with agreed upon reasonable overhead and profit.

## EXHIBIT A

### Insurance Requirements

Worker's Compensation:

STATUTORY coverage for all persons whom the CONTRACTOR may employ directly or through subcontractors in carrying out the WORK under this CONTRACT. Such insurance shall hold the VILLAGE free and harmless of all personal injuries of all persons whom the CONTRACTOR may employ directly or through Subcontractors.

Employers Liability:

\$500,000 minimum liability

Comprehensive General Liability; including Bodily Injury and Property Damage:

\$1,000,000 Each Occurrence - Combined Single Limit

\$2,000,000 Aggregate - Completed Operations

\$2,000,000 Each Occurrence - Blanket Contractual Liability

.4 Comprehensive Automobile Liability, Owned, Non-owned and Hired:

\$1,000,000 for Combined Single Limit

.5 Umbrella/Excess Liability:

\$5,000,000 Each Occurrence

INDEX  
FOR  
SUPPLEMENTAL SPECIFICATIONS  
AND RECURRING SPECIAL PROVISIONS

Adopted January 1, 2010

This index contains a listing of SUPPLEMENTAL SPECIFICATIONS and frequently used RECURRING SPECIAL PROVISIONS.

ERRATA Standard Specifications for Road and Bridge Construction (Adopted 1-1-07) (Revised 1-1-10)

SUPPLEMENTAL SPECIFICATIONS

<u>Std. Spec. Sec.</u>	<u>Page No.</u>
201 Clearing, Tree Removal and Protection .....	1
205 Embankment .....	2
251 Mulch .....	3
253 Planting Woody Plants .....	4
280 Temporary Erosion Control .....	6
406 Hot-Mix Asphalt Binder and Surface Course .....	7
443 Reflective Crack Control Treatment .....	12
502 Excavation for Structures .....	15
503 Concrete Structures .....	16
504 Precast Concrete Structures .....	17
505 Steel Structures .....	18
540 Box Culverts .....	19
581 Waterproofing Membrane System .....	20
630 Steel Plate Beam Guardrail .....	21
633 Removing and Reerecting Guardrail and Terminals .....	22
637 Concrete Barrier .....	23
669 Removal and Disposal of Regulated Substances .....	24
672 Sealing Abandoned Water Wells .....	25
701 Work Zone Traffic Control and Protection .....	26
720 Sign Panels and Appurtenances .....	27
721 Sign Panel Overlay .....	28
722 Demountable Sign Legend Characters and Arrows .....	29
726 Mile Post Marker Assembly .....	30
733 Overhead Sign Structures .....	31
783 Pavement Marking and Marker Removal .....	32
801 Electrical Requirements .....	33
805 Electrical Service Installation – Traffic Signals .....	34
836 Pole Foundation .....	35
838 Breakaway Devices .....	36
862 Uninterruptable Power Supply .....	37
873 Electric Cable .....	39
878 Traffic Signal Concrete Foundation .....	41
1003 Fine Aggregates .....	42
1004 Coarse Aggregates .....	43
1005 Stone and Broken Concrete .....	44
1006 Metals .....	45
1008 Structural Steel Coatings .....	47
1010 Finely Divided Materials .....	48
1020 Portland Cement Concrete .....	49
1022 Concrete Curing Materials .....	58
1024 Nonshrink Grout .....	59

1030 Hot-Mix Asphalt .....	60
1032 Bituminous Materials .....	65
1042 Precast Concrete Products .....	68
1062 Reflective Crack Control System .....	70
1069 Pole and Tower .....	72
1074 Control Equipment .....	75
1076 Wire and Cable .....	80
1080 Fabric Materials .....	81
1081 Materials for Planting .....	82
1083 Elastomeric Bearings .....	84
1090 Sign Base .....	85
1091 Sign Face .....	87
1092 Sign Legend and Supplemental Panels .....	95
1093 Sign Supports .....	96
1094 Overhead Sign Structures .....	98
1095 Pavement Markings .....	104
1101 General Equipment .....	106
1102 Hot-Mix Asphalt Equipment .....	107
1103 Portland Cement Concrete Equipment .....	109
1106 Work Zone Traffic Control Devices.....	110



IDOT CHECK SHEET  
FOR  
RECURRING SPECIAL PROVISIONS

Adopted January 1, 2010

The following RECURRING SPECIAL PROVISIONS indicated by an "X" are applicable to this contract and are included by reference:

<u>CHECK SHEET #</u>	<u>RECURRING SPECIAL PROVISIONS</u>	<u>PAGE NO.</u>
1	Additional State Requirements for Federal-aid Construction Contracts (Eff. 2-1-69) (Rev. 1-1-10) .....	111
2	Subletting of Contracts (Federal Aid Contracts) (Eff. 1-1-88) (Rev. 5-1-93) .....	114
3	EEO (Eff. 7-21-78) (Rev. 11-18-80) .....	115
4	Specific Equal Employment Opportunity Responsibilities Non Federal-aid Contracts (Eff. 3-20-69) (Rev. 1-1-94) .....	125
5	Required Provisions - State Contracts (Eff. 4-1-65) (Rev. 1-1-10) .....	130
6	<b>Reserved</b> .....	135
7	<b>Reserved</b> .....	136
8	Haul Road Stream Crossings, Other Temporary Stream Crossings, and In-Stream Work Pads (Eff. 1-2-92) (Rev. 1-1-98) .....	137
9	Construction Layout Stakes Except for Bridges" (Eff. 1-1-99) (Rev. 1-1-09) .....	138
10	Construction Layout Stakes (Eff. 5-1-93) (Rev. 1-1-07) .....	141
11	Use of Geotextile Fabric for Railroad Crossing (Eff. 1-1-95) (Rev. 1-1-07) .....	144
12	Subsealing of Concrete Pavements (Eff. 11-1-84) (Rev. 1-1-07) .....	146
13	Hot-Mix Asphalt Surface Removal (Cold Milling) (Eff. 11-1-87) (Rev. 1-1-09) .....	150
14	Pavement and Shoulder Resurfacing (Eff. 2-1-02) (Rev. 1-1-09) .....	152
15	PCC Partial Depth Hot-Mix Asphalt Patching (Eff. 1-1-98) (Rev. 1-1-07) .....	153
16	Patching with Hot-Mix Asphalt Overlay Removal (Eff. 10-1-95) (Rev. 1-1-07) .....	155
17	Polymer Concrete (Eff. 8-1-95) (Rev. 1-1-08) .....	156
18	PVC Pipeliner (Eff. 4-1-04) (Rev. 1-1-07) .....	158
19	Pipe Underdrains (Eff. 9-9-87) (Rev. 1-1-07) .....	159
20	Guardrail and Barrier Wall Delineation (Eff. 12-15-93) (Rev. 1-1-97) .....	160
21	Bicycle Racks (Eff. 4-1-94) (Rev. 1-1-07) .....	164
22	Temporary Modular Glare Screen System (Eff. 1-1-00) (Rev. 1-1-07) .....	166
23	Temporary Portable Bridge Traffic Signals (Eff. 8-1-03) (Rev. 1-1-07) .....	168
24	Work Zone Public Information Signs (Eff. 9-1-02) (Rev. 1-1-07) .....	170
25	Night Time Inspection of Roadway Lighting (Eff. 5-1-96) .....	171
26	English Substitution of Metric Bolts (Eff. 7-1-96) .....	172
27	English Substitution of Metric Reinforcement Bars (Eff. 4-1-96) (Rev. 1-1-03) .....	173
28	Calcium Chloride Accelerator for Portland Cement Concrete (Eff. 1-1-01) .....	174
29	<b>Reserved</b> .....	175
30	QC of Concrete Mixtures at the Plant (Eff. 8-1-00) (Rev. 1-1-09) .....	176
31	Quality Control/Quality Assurance of Concrete Mixtures (Eff. 4-1-92) (Rev. 1-1-09) .....	184
32	Asbestos Bearing Pad Removal (Eff. 11-1-03) .....	196
33	Asbestos Hot-Mix Asphalt Surface Removal (Eff. 6-1-89) (Rev. 1-1-09) .....	197

IDOT CHECK SHEET  
FOR  
RECURRING LOCAL ROADS AND STREETS SPECIAL PROVISIONS

Adopted January 1, 2010

The following RECURRING LOCAL ROADS AND STREETS SPECIAL PROVISIONS indicated by an "X" are applicable to this contract and are included by reference:

<u>CHECK SHEET #</u>	<u>RECURRING LOCAL ROADS AND STREETS SPECIAL PROVISIONS</u>	<u>PAGE NO.</u>
LRS 1	<b>Reserved</b> .....	199
LRS 2	Furnished Excavation (Eff. 1-1-99) (Rev. 1-1-07) .....	200
LRS 3	X Work Zone Traffic Control (Eff. 1-1-99) (Rev. 1-1-10) .....	201
LRS 4	Flaggers in Work Zones (Eff. 1-1-99) (Rev. 1-1-07) .....	202
LRS 5	X Contract Claims (Eff. 1-1-02) (Rev. 1-1-07) .....	203
LRS 6	X Bidding Requirements and Conditions for Contract Proposals (Eff. 1-1-02) .....	204
LRS 7	Bidding Requirements and Conditions for Material Proposals (Eff. 1-1-02) (Rev. 1-1-03) .....	210
LRS 8	Failure to Complete the Work on Time (Eff. 1-1-99) .....	216
LRS 9	Bituminous Surface Treatments (Eff. 1-1-99) .....	217
LRS 10	<b>Reserved</b> .....	218
LRS 11	X Employment Practices (Eff. 1-1-99) .....	219
LRS 12	Wages of Employees on Public Works (Eff. 1-1-99) (Rev. 1-1-10) .....	221
LRS 13	X Selection of Labor (Eff. 1-1-99) .....	222
LRS 14	X Paving Brick and Concrete Paver Pavements and Sidewalks (Eff. 1-1-04) (Rev. 1-1-09) .....	223
LRS 15	Partial Payments (Eff. 1-1-07) .....	226

## SPECIAL PROVISIONS

### DETECTABLE WARNING PLATE

#### Application:

This pay item is for the installation of cast iron detectable warning plates to be installed in the replaced sections of concrete sidewalk at areas where the public walk blends with vehicular ways, or as directed by the Village. The installation of these plates shall conform to Section 424 of the *Illinois Department of Transportation Standard Specifications for Road and Bridge Construction*, latest edition, and the Americans with Disabilities Act Accessibility Guidelines. Exact locations will be indicated in the field by the Village, and the number of detectable warning plates per project area is shown on the project plan sheet(s).

#### Materials:

New, 24"x24" gray cast iron detectable warning plates (East Jordan Iron Works 7005 Series with the Black Asphalt dip finish or approved equal) shall be manufactured in accordance with ADA Accessibility Guidelines for Detectable Warnings. All plates shall be delivered to the job site with the manufacturer coated, black colored finish to reduce corrosion.

#### General procedure of work:

1. Remove and replace sidewalk as indicated per pay item 2, Remove & Replace 5 in. P.C.C. Sidewalk.
2. Set cast iron detectable warning plate into wet concrete. Typically, two plates will be set side-by-side, centered across a five foot wide walk, within six inches behind the back of curb and perpendicular to the pedestrian path of travel.
3. Tamp plate thoroughly with rubber mallet to ensure that no air pockets remain under the plate. All lugs shall be completely encased in concrete. Concrete shall seep through vent holes until it is filled flush with the plate. All edges of the plates shall be flush with the adjacent concrete.
4. Clean any excess concrete off plate.
5. Broom finish the concrete left exposed around the plate.

#### Basis of Payment:

This work will be paid for at the contract unit price per EACH plate for DETECTABLE WARNING PLATE.

### REPAIR OF CONCRETE VIA THE PNEUMATIC PLACEMENT METHOD (PNEUMATIC CURB REPAIR)

#### Application:

This pay item is similar to Section 585- Epoxy Mortar Repair, from the Illinois Department Of Transportation (IDOT) Standard Specifications for Road and Bridge Construction, Jan. 1 2002, and shall be used for repairing or depressing short sections of existing concrete curb & gutter.

#### Materials:

The cement, water, and aggregates for pneumatic concrete shall conform to the requirements of articles 1001-1004 of the latest edition of the IDOT Standard Specifications and ACI standard 506-66.

**Equipment:**

The cement gun for the pneumatically placed mortar shall be of the wet-mix pressure vessel type similar to the Sprayton Gun, True Gun-All model, or an equal approved by the Village. The compressor shall be of sufficient capacity to provide enough air pressure to operate the concrete placing machine at rated capacity.

The concrete placing machine shall be of the type where the water can be accurately gauged and mixed with dry materials in a mixing chamber under air pressure. The mixed material shall be fed by air pressure through a hose connected to a positive shut-off trigger type nozzle to insure complete hydration of the materials.

**General Procedure of Work:**

1. All exterior concrete surfaces shall be thoroughly examined by means of sounding with hammers to determine loose or defective areas that may exist.
2. Where such defective concrete surfaces exist, these areas are to be removed by use of air hammers or other mechanical tools to a depth necessary to remove all loose and disintegrated material. All exposed reinforcing bars shall be thoroughly cleaned by sandblasting. All unbonded reinforcing bars shall be undercut to a depth that will permit a minimum of one inch (1 in.) of plastic cement around the reinforcing bars.
3. After removing the unsound concrete from the surface, the contractor shall thoroughly clean the surface by sandblasting the areas involved.
4. Surfaces shall be wetted before gunning (to control suction), but any excess puddling water shall be removed.
5. The pneumatic and portland cement mortar shall be applied with the cement gun so as to form a compact, durable covering of the thickness desired. The finish shall be brushed and free of depression. The contractor shall carefully restore the original shapes and contours of the repaired sections.

**Curing:**

Curing shall be done in accordance with the applicable portions of section 1022 of the IDOT "Standard Specifications" and as directed by the Village. Membrane curing compound will also be permitted and will comply with the requirements as stated above. The contractor shall begin curing operations as soon as the concrete has hardened sufficiently to prevent marring the surface.

**Basis of Payment:**

This work will be paid for at the contract unit price per **LINEAL FOOT** for **PNEUMATIC CURB REPAIR**

## **PAVING BRICK DRIVEWAY REPAIR**

**Application:**

This pay item is for the restoration of paving brick driveways following the removal and replacement of adjacent concrete curb & gutter and/or concrete sidewalk.

**Materials:**

The replacement brick (if necessary) shall be of the same type, size, texture and color as the existing driveway brick. All other materials shall conform to IDOT Bureau of Local Roads and Streets Special Provision for Paving Brick and Concrete Paver Pavements and Sidewalks, #LRS14.

**Construction methods:**

It is recommended that at least two or three courses of the driveway bricks be removed by hand and stacked prior to the removal of concrete. This will ensure that few, if any, replacement bricks will be needed to restore the driveway. The driveway shall be restored, as close as possible, to original condition. The correct fit, pattern, consistent grading and compaction of the brick driveway pavement are of utmost importance.

**General procedure of work:**

1. Between 5-7 days of the new concrete placement, the base course of the driveway shall be restored.
2. Immediately following base course repair, the paving bricks shall be fitted to the existing driveway to restore the original grade and appearance of the driveway.
3. Additional sand shall be added to the brick joints and a vibratory plate-type compactor shall be used to solidify the brick pavement.

**Basis of Payment:**

This work will be paid for at the contract unit price per **SQUARE FOOT** for **PAVER BRICK DRIVEWAY REPAIR**.

## **HMA IMPRINTED ASPHALT DRIVEWAY PAVEMENT REPAIR**

**Application:**

This pay item is for the repair (removal and replacement) of imprinted asphalt driveway sections, following the removal and replacement of adjacent concrete sidewalk and/or concrete curb & gutter. The contractor performing this work shall be a licensed and qualified HMA imprinted paving contractor approved by the Village.

**Materials:**

The asphalt mix shall be of the Bituminous Concrete Surface Course, Superpave, Mix "C" N50 type, and shall meet the requirements of Section 406, IDOT Standard Specifications. The coating products shall be those specifically developed for use over imprinted asphalt pavement, such as StreetBond products or equivalent.

**Equipment:**

Templates for work shall be flexible, woven wire rope, cut and welded in various patterns, that is to be used specifically for imprinting hot mix asphalt. Asphalt heaters, if needed, shall be of the infra-red or hot air type. Direct flame heaters will not be allowed.

**General procedure of work:**

*Asphalt Replacement:*

The driveway shall be sawcut in a manner that will allow the best matching of the existing imprinted pattern. The asphalt shall be of the same thickness as the existing driveway and properly compacted before proceeding with the imprinting process.

*Imprinting:*

The imprinted pattern shall match the existing pattern and shall be of consistent depth. Imprinting can proceed immediately after the hot asphalt has been placed and compacted, while the asphalt is still in a warm/hot pliable state. Alternatively, imprinting can be carried out at a later stage, on existing asphalt, by applying heat to the asphalt surface to make the upper portion of the asphalt surface pliable enough to accept the imprint of the template. The application of heat to existing asphalt surface shall be done using re-heating equipment, such as infra red heaters or hot air heaters. Overheating of the asphalt shall not be permitted. It is recommended that the temperature of the asphalt surface be regularly monitored during the reheating process, to avoid overheating and degradation of the asphalt cement.

*Coatings:*

Prior to the application of coatings, the asphalt surface shall be free of all dirt, debris, fluids or anything that will prevent a proper bond of the coating. If dirt is to be removed, the asphalt surface shall be pressure washed and allowed to dry completely before any coating is applied. The contractor shall apply the coating product(s) only when the ambient air temperature is at least 50°F (10°C) and rising, and when the ambient temperature will not drop below 50°F (10°C) within 8 hours of application of the coating. There should be no precipitation expected within 12 hours after applying the final top coat.

**Basis of Payment:**

This work will be paid for at the contract unit price per **SQUARE YARD** of pavement for **HMA TEXTURED ASPHALT DRIVEWAY PAVEMENT REPAIR**

**Hot In-Place Pavement Recycling**

**Application:**

This work will consist of rehabilitating existing hot mix asphalt by sweeping, heating, scarifying with flexible tines, adding rejuvenating agent, remixing, shaping, and compacting the mixture in a single operation. The finished product will serve as a leveling course to be overlaid with Hot-Mix Asphalt Surface Course, Mix C, N50 (Item 31).

**Construction Requirements:**

Pavement Recycling will be performed only when weather conditions are suitable, when the air temperature in the shade is at least 45°F (8°C) and the forecast is for rising temperatures. Prior to the Recycling operation, the pavement area to be recycled shall be cleaned and swept at no additional cost. The pavement shall be dry and free of any foreign material including earth, cold mix patching material, crack sealant, thermoplastic pavement marking, or other material as directed by the Village. Any base failure will be repaired prior to construction and paid for as Class D Patches- Various Types (Item 21).

**Equipment and Construction Requirements:**

The surface of the existing pavement shall be heated with continuously moving radiant type heater(s) to allow the pavement to be scarified, without fracturing of aggregate with the surface temperature of the old pavement not to exceed 375F. The pavement shall be scarified to a minimum depth of 3/4 inch (20 mm). This will yield an approximately a weight of 9 lb/sq ft (48 kg/sq m) of loose material. Heat shall be applied under an enclosed or shielded hood and shall extend at least 6 inches (150 mm) beyond the width of recycling on both sides. After heating, the scarification shall dislodge but not fracture aggregate to the specified depth. The heating and scarification operation shall not exceed a forward speed of 25 ft (8 m) per minute. When a recycling pass is being made adjacent to a previously recycled mat, the longitudinal recycling seam shall extend at least 2 inches into the previously recycled mat.

Immediately after primary scarification, a rejuvenating agent, approved by the Department, shall be applied at a nominal application rate as specified by an independent materials consultant per square yard. The rate of application shall be automated to maintain the specified application rate in relation to the operating speed of the recycling machine and shall be maintained at a tolerance of not greater than 5% above or below the designated application rate. The machine shall include equipment and instrumentation to monitor and report the rate of application of the rejuvenating agent. A hand spray system for tacking hand-paved areas shall be provided. Adjustment of the application rate shall be made as changes are required to compensate for variations of the residual asphalt content in the scarified pavement as determined by the Engineer. The contractor is responsible for supplying a testing report to document the application rate. A minimum of 1 core and test is required for each mile of pavement to be scarified. The cost of the testing and reports will be borne by the contractor and furnished to the engineer prior to the start of the heater scarifying.

Immediately after scarifying and mixing, the mixture shall be leveled. The spreading and finishing section of the recycling machine shall be capable of spreading and finishing the surface in lane widths. The screed shall effectively produce a uniform finished surface without tearing, shoving, or gouging of the mix.

The process, either with individual machines or with a self-contained recycling machine shall protect or supplement the heat of the mixture to provide a mixture behind the screed with a temperature range of 220 to 320 °F (105 to 160 °C). Scarifying shall be accomplished with pressure scarifiers. The scarifying unit shall be equipped to scarify and move materials away from the gutter flags for a depth of 1/2 inch by 4 inches wide. Compaction shall be accomplished with a self-propelled pneumatic roller meeting requirements of Article 1101.1(c). Recompacting of the scarified pavement shall be performed immediately following the application of the rejuvenating agent. Compaction equipment shall have a minimum static weight of 10 tons. The density of the finished surface shall be to the satisfaction of the Engineer.

Following the HST operation, a uniform layer of hot mix bituminous surface mixture meeting the requirements of Section 406 shall be applied. The finishing machine or paver shall be capable of spreading and finishing the surface in lane widths to the specified cross section and thickness. The vibratory screed or strike-off assembly shall effectively produce a finished surface of the required uniform slope and texture without tearing, shoving or gouging the mix. The screed shall be adjustable to taper the finished surface to the height of the gutter flag. The surface shall be compacted thoroughly and uniformly with a pneumatic-tired roller followed by a tandem finish roller meeting the requirements of Article 1101.01(c) and 1101.01 (e) of the Standard Specifications. The spreading and finishing machine shall be operated at a speed that will insure, as near as possible, continuous operation not to exceed 35 feet per minute.

**Whenever practical, the new wearing surface shall be applied to all heater scarified and rejuvenated areas by the close of each working day.** Heater scarifying and rejuvenation will be suspended when, in the judgment of the field engineer, a period of delay in excess of two hours before the application of the new wearing surface is contemplated. In no case shall heater scarified streets be allowed to remain unpaved for more than **24 hours**. Only one street may be allowed to remain unpaved overnight.

**All streets shall have the final surface course placed prior to the weekend.** No Saturday work shall be allowed unless permission is granted to the contractor in writing by the Village.

Determination of the actual depth and weight of milled surface shall be as follows:

- At locations determined by The Engineer, a ring test shall be performed, by the contractor and witnessed by The Engineer, directly behind the recycling paving train, and before the breakdown roller has passed the specified location.
- A metal ring of known internal area (1 sq ft (0.1 sq m) suggested), and with sufficient rigidity to penetrate the loosened material shall then be pushed into the loosened mat.
- The loosened material within the ring shall be removed with a small scoop and a brush.
- The removed material shall be weighed, and the pounds per square foot (kilograms per square meter) of recycled material shall be calculated.
- This process shall be performed on site for each 1/4 mile (0.4 km) of each lane.
- Once a ring test is determined, the material shall be replaced and the test area shall be struck level before any roller passes.
- Should a ring test yield less than 9 lb/sq ft (44 kg/sq m) the contractor shall take cores at locations determined by The Engineer, to determine the recycled mat thickness.
- The Engineer may, and the Contractor shall monitor the recycling thickness on an ongoing basis by probing or by other means. If at any time the required recycling thickness is not being met, the contractor shall take corrective actions. If the variation from the target recycling thickness and/or mixture properties is excessive or goes uncorrected, the Engineer reserves the right to suspend operations until the probable cause(s) of the deficiencies are corrected.

**Method of Measurement:**

The recycling process, including rejuvenating agent will be measured for payment in place and the area computed in square yards (square meters).

**Basis of Payment:**

This work will be paid for at the contract unit price per square yard for HOT IN-PLACE PAVEMENT RECYCLING, and per TON for HOT-MIX ASPHALT SURFACE COURSE, MIX "C", N50.

## **Paving Brick Pavement**

**Application:**

This pay item will include all material and labor required to install the paving brick in the two sections of center median on 149<sup>th</sup> Street near LaGrange Road as shown on the plans. This work shall be performed by an experienced installer who has completed paving brick installations similar in material and design.

**Construction Requirements:**

All work shall conform to IDOT Supplemental Specifications and Recurring Special Provisions, #LRS14 Paving Brick and Concrete Paver Pavements and Sidewalks. The paving brick shall be laid in a Running Bond Pattern with one row Soldier Course around the perimeter of the median adjacent to the back of curb. Mix bricks from several pallets or cubes, as they are placed, to produce a uniform blend of colors and textures. Use full bricks without cutting where possible. Cut bricks with a masonry saw to provide clean, sharp, unchipped edges and fit to adjoining work neatly. Follow all manufacturers' installation recommendations, including any edge restraints and joints, placement and material.

**Materials:**

The paving bricks shall closely resemble the appearance (type, size, texture and color) of the existing paving brick sidewalk alongside the 143<sup>rd</sup> Street Orland Park Metra Station located near the northwest corner of 143<sup>rd</sup> Street and LaGrange Road (Route 45).

**Scope of Work**

This work will include all material and labor required to complete the work as shown on the Plan and specified above. The existing concrete medians will be removed and paid as Earth Excavation. The proposed curb will also be paid separately, Curb & Gutter, B-6.12 (Item #06). The preparation of the remaining base and all aggregate associated with the brick installation are considered part of this pay item.

**Basis of Payment:**

This work will be paid for at the contract unit price per **SQUARE FOOT** for **PAVING BRICK PAVEMENT**.



## **ADJUST & REMORTAR STRUCTURE FRAME**

### **Application:**

This pay item is for the adjustment of existing utility structures within the right-of-way. The servicing of designated structures shall conform to Section 602 of the *Illinois Department of Transportation Standard Specifications for Road and Bridge Construction*, latest edition. Exact locations of structures to be adjusted will be indicated in the field by the Village Engineer, and the number of adjustments per project area is shown on the project plan sheet(s).

### **Materials:**

1. New, crack-free concrete adjustment risers shall conform to ASTM C478.
2. Rubber adjustment risers (Infra-Riser brand or approved equal) shall be manufactured in accordance with ASTM D1248. Recycled materials meeting the requirements of ASTM D1248 may be used.

### **Adjusting Requirements:**

1. Any designated adjustment shall use at least one rubber adjustment riser (Infra-Riser brand or approved equal) to establish the final seating surface of the structure frame. If necessary, said riser shall be of the tapered type in order to match the grade of the roadway
2. No more than two (2) rubber adjustment risers with three (3) inches total maximum rubber-adjusted height shall be allowed.
3. Adjustment less than three (3) inches in height shall consist of only rubber adjustment riser(s). The minimum thickness of a rubber adjustment riser shall be one (1) inch.
4. Adjustment greater than three (3) inches in height shall use a pre-cast concrete riser for the lower riser, and the final riser shall be of the rubber type.

### **Sealing:**

All non-rubber mating surfaces, exterior joints of frames, adjustment riser(s), flat slab top or cone section (if applicable) and structure section shall be sealed with a uniform application of bituminous mastic sealant. The mating surfaces of all rubber adjustment risers shall be sealed with the manufacturer's recommended sealant for rubber adjustment risers. If multiple adjustment risers are required, a continuous application of sealant shall be applied between each unit. Interior surfaces shall be sealed with concrete mortar or epoxy mortar. Concrete mortar or epoxy mortar will not be used on mating surfaces as a sealant between adjustment risers, structure sections or frames.

### **General procedure of work:**

1. Structure frame and grate shall be reused unless deemed to be defective by the Village.
2. All compromised adjusting risers shall be removed from the structure and discarded
3. All existing loose mortar and other foreign material shall be completely removed from the structure prior to application of the new sealant. The sealant shall be applied to a clean and undamaged surface to achieve a smooth finish suitable for seating adjustment risers.
4. Upon installation, adjusting riser(s) shall be concentric with the frame and the slab opening itself.
5. The structure frame shall be set at an elevation to substantially match the cross-slope of the roadway and existing curb grade, or the existing grade.
6. Fresh mortar shall be applied to those interior areas of the structure that may allow leakage to occur.
7. All loose material shall be removed from the bottom of the structure.
8. A map showing the locations of the serviced structures shall be provided to the Village upon completion of the work.

### **Basis of Payment:**

This work will be paid for at the contract unit price per each structure serviced for **ADJUST & REMORTAR STRUCTURE FRAME**.

## **RECONSTRUCT MANHOLE, BLOCK**

### **Application:**

This pay item is for the reconstruction of existing utility structures within the right-of-way. The servicing of designated structures shall conform to Section 602 of the *Illinois Department of Transportation Standard Specifications for Road and Bridge Construction*, latest edition. Exact locations of structures to be adjusted will be indicated in the field by the Village Engineer, and the number of adjustments per project area is shown on the project plan sheet(s).

### **Materials:**

1. New, concrete masonry units shall conform to ASTM C139.
2. New, crack-free concrete adjustment risers shall conform to ASTM C478
3. Rubber adjustment risers (Infra-Riser brand or approved equal) shall be manufactured in accordance with ASTM D1248. Recycled materials meeting the requirements of ASTM D1248 may be used.

### **Adjusting Requirements:**

1. Any designated adjustment shall use at least one rubber adjustment riser (Infra-Riser brand or approved equal) to establish the final seating surface of the structure frame. If necessary, said riser shall be of the tapered type in order to match the grade of the roadway
2. No more than two (2) rubber adjustment risers with three (3) inches total maximum rubber-adjusted height shall be allowed.
3. Adjustment less than three (3) inches in height shall consist of only rubber adjustment riser(s). The minimum thickness of a rubber adjustment riser shall be one (1) inch.
4. Adjustment greater than three (3) inches in height shall use a pre-cast concrete riser for the lower riser, and the final riser shall be of the rubber type.

### **Sealing:**

All mating surfaces and interior and exterior joints between concrete masonry units shall be sealed with a uniform application of mortar. All other non-rubber mating surfaces, exterior joints of frames, adjustment riser(s), flat slab top or cone section (if applicable) and structure section shall be sealed with a uniform application of bituminous mastic sealant. The mating surfaces of all rubber adjustment risers shall be sealed with the manufacturer's recommended sealant for rubber adjustment risers. If multiple adjustment risers are required, a continuous application of sealant shall be applied between each unit. Interior surfaces shall be sealed with concrete mortar or epoxy mortar. Concrete mortar or epoxy mortar will not be used on mating surfaces as a sealant between adjustment risers or frames.

### **General procedure of work:**

1. Structure frame and grate shall be reused unless deemed to be defective by the Village Engineer.
2. All compromised adjusting risers and masonry units shall be removed from the structure and discarded.
3. All existing loose mortar, masonry units, and other foreign material shall be completely removed from the structure prior to application of the new mortar and concrete masonry units. The mortar shall be applied to a clean and undamaged surface to achieve a smooth finish suitable for seating concrete masonry units.
4. Upon installation, adjusting riser(s) shall be concentric with the frame and the slab opening itself.
5. The structure frame shall be set at an elevation to substantially match the cross-slope of the roadway and existing curb grade, or the existing grade.
6. Fresh mortar shall be applied to those interior areas of the structure that may allow leakage to occur.
7. All loose material shall be removed from the bottom of the structure.
8. A map showing the locations of the serviced structures shall be provided to the Village upon completion of the work.

**Basis of Payment:**

This work will be paid for at the contract unit price per each structure serviced for **RECONSTRUCT MANHOLE, BLOCK.**

**RECONSTRUCT MANHOLE, CONE SECTION**

**Application:**

This pay item is for the adjustment of existing utility manhole structures within the paved roadway. The servicing of designated manholes shall conform to Section 602 of the *Illinois Department of Transportation Standard Specifications for Road and Bridge Construction*, latest edition. Exact locations of structures to be adjusted will be indicated in the field by the Village Engineer, and the number of adjustments per project area is shown on the project plan sheet(s).

**Materials:**

1. Structure adjustment shall require replacement of the existing eccentric cone section and any existing adjusting riser(s).
2. Any designated adjustment shall use at least one rubber adjustment riser (Infra-Riser brand or approved equal) to establish the final seating surface of the structure frame. If necessary, said riser shall be of the tapered type in order to match the grade of the roadway
3. No more than two (2) rubber adjustment risers with three (3) inches total maximum rubber-adjusted height shall be allowed.
4. Adjustment less than three (3) inches in height shall consist of only rubber adjustment riser(s). The minimum thickness of a rubber adjustment riser shall be one (1) inch.
5. Adjustment greater than three (3) inches in height shall use a pre-cast concrete riser for the lower riser, and the final riser shall be of the rubber type.

**Sealing:**

All non-rubber mating surfaces, exterior joints of frames, adjustment riser(s), cone section and structure section shall be sealed with a uniform application of bituminous mastic sealant. The mating surfaces of all rubber adjustment risers shall be sealed with the manufacturer's recommended sealant for rubber adjustment risers. If multiple adjustment risers are required, a continuous application of sealant shall be applied between each unit. Interior surfaces shall be sealed with concrete mortar or epoxy mortar. Concrete mortar or epoxy mortar will not be used on mating surfaces as a sealant between adjustment risers, structure sections or frames.

**General procedure of work:**

1. Structure frame and grate shall be reused unless deemed to be defective by the Village.
2. All compromised adjusting riser(s) and the cone section shall be removed from the structure and discarded.
3. All existing loose mortar and other foreign material shall be completely removed from the structure prior to application of the new sealant. The sealant shall be applied to a clean and undamaged surface to achieve a smooth finish suitable for seating adjustment risers.
4. Upon installation, adjusting riser(s) shall be concentric with the frame and the slab opening itself.
5. The structure frame shall be set at an elevation to substantially match the cross-slope of the roadway and existing curb grade, or the existing grade.
6. Fresh mortar shall be applied to those interior areas of the structure that may allow leakage to occur.
7. All loose material shall be removed from the bottom of the structure.
8. A map showing the locations of the serviced structures shall be provided to the Village upon completion of the work.

**Basis of Payment:**

This work will be paid for at the contract unit price per EACH structure serviced for RECONSTRUCT MANHOLE, CONE SECTION.

**RECONSTRUCT MANHOLE, FLAT SLAB**

**Application:**

This pay item is for the adjustment of existing utility manhole structures within the paved roadway. The servicing of designated manholes shall conform to Section 602 of the *Illinois Department of Transportation Standard Specifications for Road and Bridge Construction*, latest edition. Exact locations of structures to be adjusted will be indicated in the field by the Village Engineer, and the number of adjustments per project area is shown on the project plan sheet(s).

**Materials:**

1. Structure adjustment shall require replacement of the existing flat slab top section and any existing adjusting riser(s).
2. Any designated adjustment shall use at least one rubber adjustment riser (Infra-Riser brand or approved equal) to establish the final seating surface of the structure frame. If necessary, said riser shall be of the tapered type in order to match the grade of the roadway
3. No more than two (2) rubber adjustment risers with three (3) inches total maximum rubber-adjusted height shall be allowed.
4. Adjustment less than three (3) inches in height shall consist of only rubber adjustment riser(s). The minimum thickness of a rubber adjustment riser shall be one (1) inch.
5. Adjustment greater than three (3) inches in height shall use a pre-cast concrete riser for the lower riser, and the final riser shall be of the rubber type.

**Sealing:**

All non-rubber mating surfaces, exterior joints of frames, adjustment riser(s), flat slab top section and structure section shall be sealed with a uniform application of bituminous mastic sealant. The mating surfaces of all rubber adjustment risers shall be sealed with the manufacturer's recommended sealant for rubber adjustment risers. If multiple adjustment risers are required, a continuous application of sealant shall be applied between each unit. Interior surfaces shall be sealed with concrete mortar or epoxy mortar. Concrete mortar or epoxy mortar will not be used on mating surfaces as a sealant between adjustment risers, structure sections or frames.

**General procedure of work:**

1. Structure frame and grate shall be reused unless deemed to be defective by the Village.
2. All compromised adjusting riser(s) and the flat slab top section shall be removed from the structure and discarded.
3. All existing loose mortar and other foreign material shall be completely removed from the structure prior to application of the new sealant. The sealant shall be applied to a clean and undamaged surface to achieve a smooth finish suitable for seating adjustment risers.
4. Upon installation, adjusting riser(s) shall be concentric with the frame and the slab opening itself.
5. The structure frame shall be set at an elevation to substantially match the cross-slope of the roadway and existing curb grade, or the existing grade.
6. Fresh mortar shall be applied to those interior areas of the structure that may allow leakage to occur.
7. All loose material shall be removed from the bottom of the structure.
8. A map showing the locations of the serviced structures shall be provided to the Village upon completion of the work.

**Basis of Payment:**

This work will be paid for at the contract unit price per **EACH** structure serviced for **RECONSTRUCT MANHOLE, FLAT SLAB**.

**RE-MORTAR STRUCTURE**

**Application:**

This pay item is for the re-mortaring of existing structures within the project right-of-way. The servicing of designated structures shall conform to Section 602 of the *Illinois Department of Transportation Standard Specifications for Road and Bridge Construction*, latest edition. Exact locations of structures to be re-mortared will be indicated in the field by the Village Engineer, and the number of re-mortars per project area is shown on the project plan sheet(s).

**General procedure of work:**

1. Re-mortaring of structures located within the pavement or curblin shall not commence until after the surface course is paved
2. All existing loose mortar and other foreign material shall be completely removed from the structure (including bottom) prior to application of the new mortar.
3. Fresh mortar shall be applied to those interior areas of the structure that may allow leakage to occur.
4. A map showing the locations of the re-mortared structures shall be provided to the Village engineer upon completion of the work.

**Basis of Payment:**

This work will be paid for at the contract unit price per **EACH** structure serviced for **RE-MORTAR STRUCTURE**

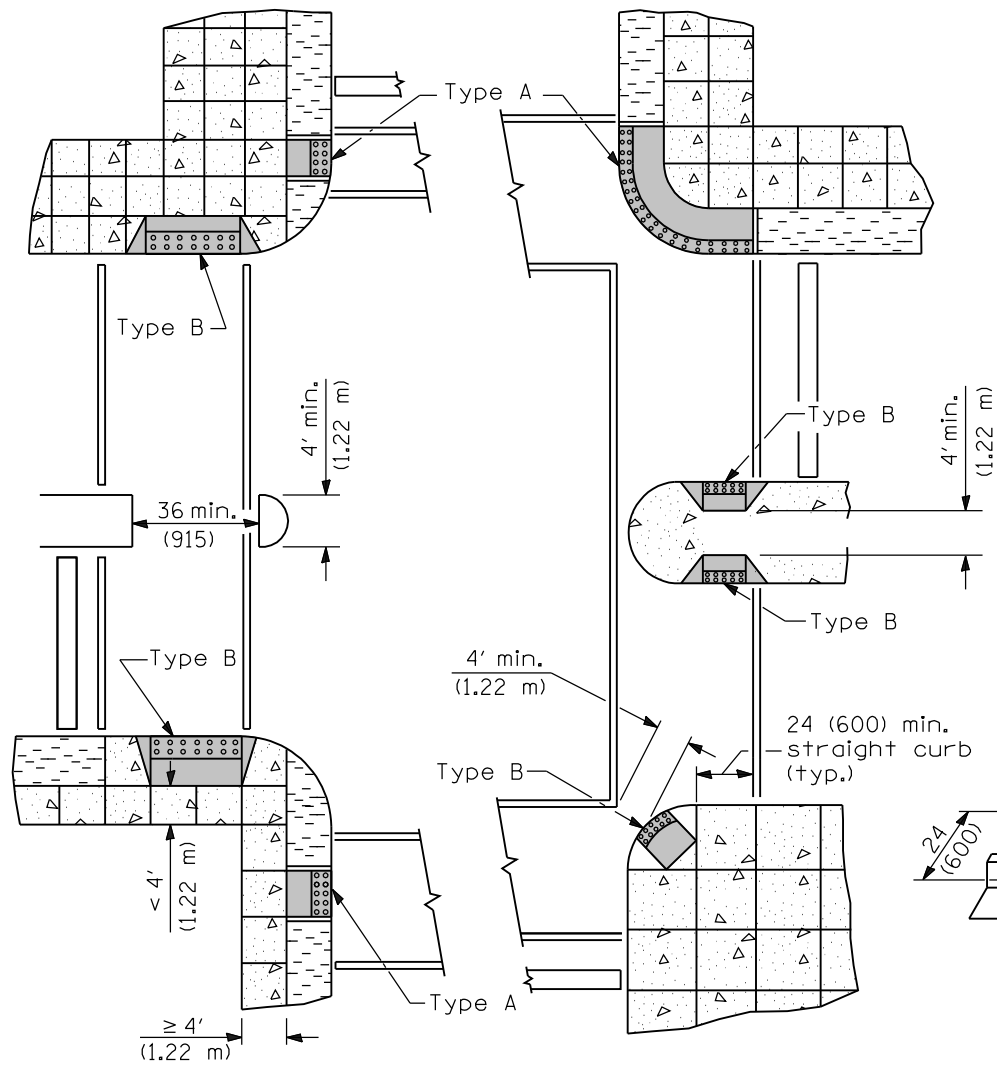

**RECOMMENDED LOCATION OF RAMPS**

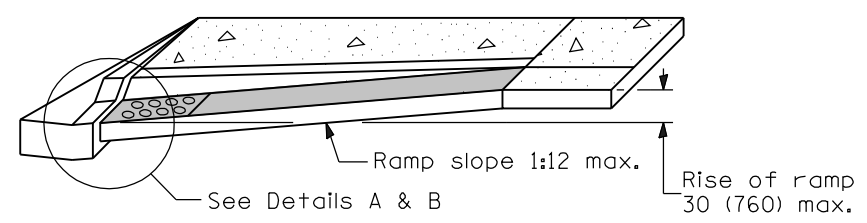

**RAMP PROFILE**

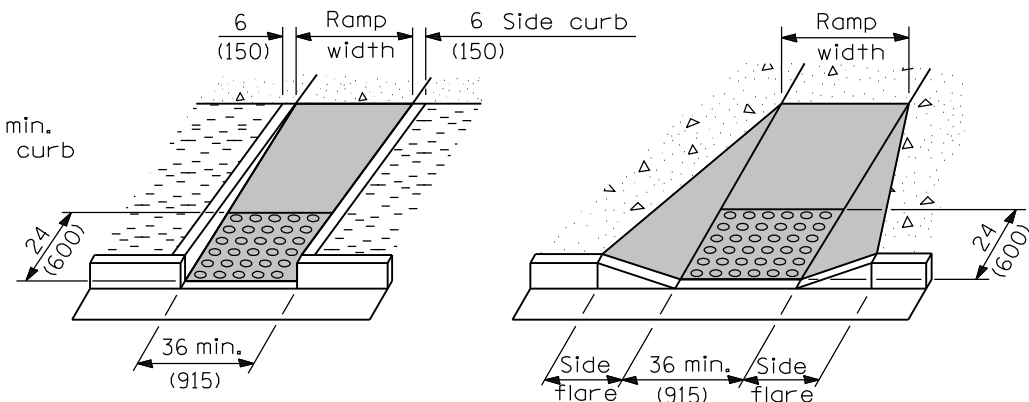

**DETAILS OF RAMPS**

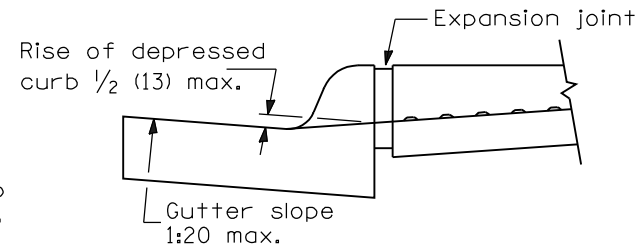

**DETAIL A**

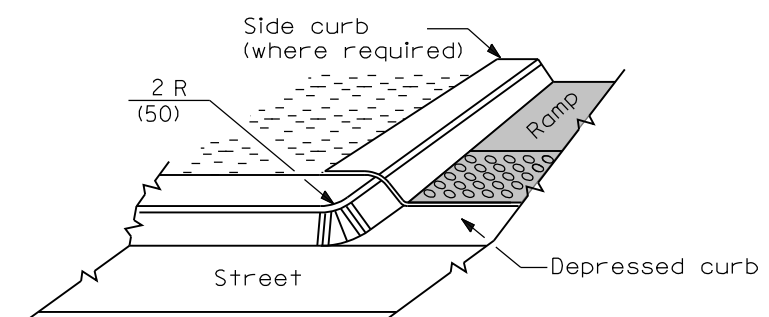

**DETAIL B**

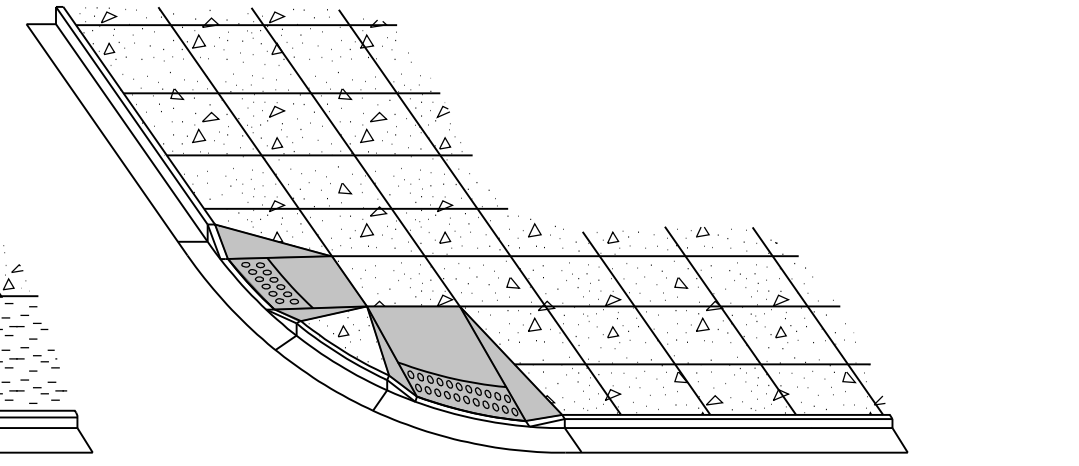

**TYPE A RAMPS**

**TYPE B RAMPS**

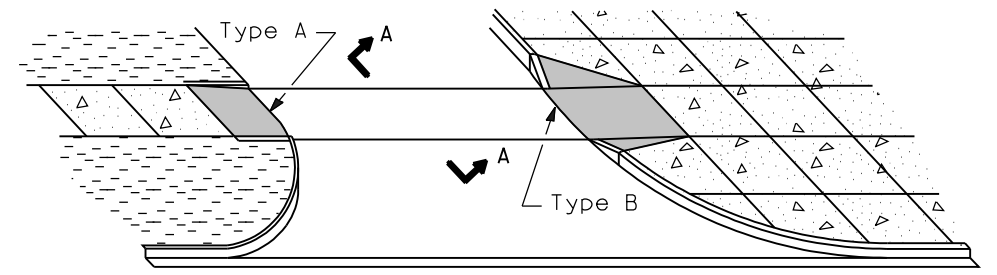

**RAMPS AT ALLEYS OR ENTRANCES**

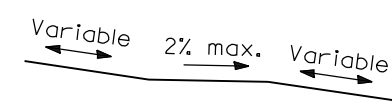

**SECTION A-A**

**GENERAL NOTES**

Detectable warnings shall be installed at curb ramps, medians and pedestrian refuge islands, at-grade railroad crossings, transit platform edges, and other locations where pedestrians are required to cross a hazardous vehicular way. Detectable warnings shall also be installed at alleys and commercial entrances when permanent traffic control devices are present.

The maximum slope of the side flare for Type B ramps shall be 1:10; however, if the width of the landing area between the top of the ramp and an obstruction is less than 4'-0" (1.22 m) then the maximum slope shall be 1:12.

All slope ratios are expressed as units of vertical displacement to units of horizontal displacement (V:H).

All dimensions are in inches (millimeters) unless otherwise shown.

Flush with top of roadway curb and top of sidewalk

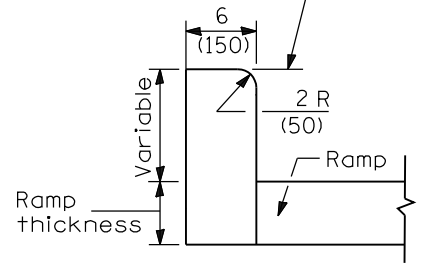

**DETAIL OF SIDE CURB**

(Side curb may be constructed monolithically with ramp)

**LEGEND**

- Sidewalk
- Ramp
- Detectable Warnings
- Non walking area

DATE	REVISIONS
1-1-08	Switched units to English (metric).
8-1-05	Revised placement of detectable warnings.
	title.

**CURB RAMPS FOR SIDEWALKS**

(Sheet 1 of 2)

**STANDARD 424001-05**

Illinois Department of Transportation  
 PASSED January 1, 2008  
 ENGINEER OF POLICY AND PROCEDURES  
 APPROVED January 1, 2008  
 ENGINEER OF DESIGN AND ENVIRONMENT

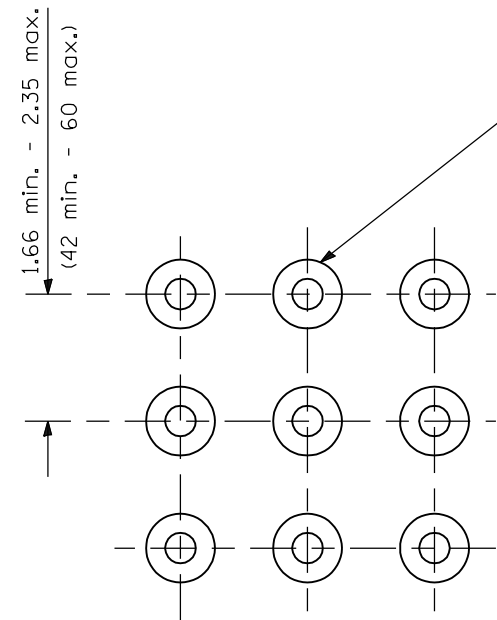

**SQUARE PATTERN**  
(Parallel Alignment)

Truncated Dome

Direction of Travel

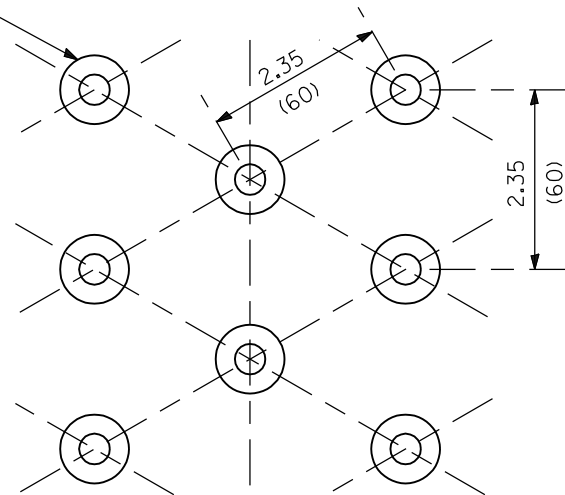

**TRIANGULAR PATTERN**

**DETECTABLE WARNINGS DETAIL**

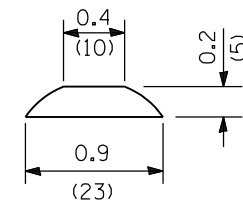

**TRUNCATED DOME DETAIL**

Illinois Department of Transportation	
PASSED <u>January 1, 2008</u> <i>Santosh</i> ENGINEER OF POLICY AND PROCEDURES	ISSUED 1-1-07
APPROVED <u>January 1, 2008</u> <i>Ken E. Han</i> ENGINEER OF DESIGN AND ENVIRONMENT	

<b>CURB RAMPS FOR SIDEWALKS</b> <small>(Sheet 2 of 2)</small>
<b>STANDARD 424001-05</b>

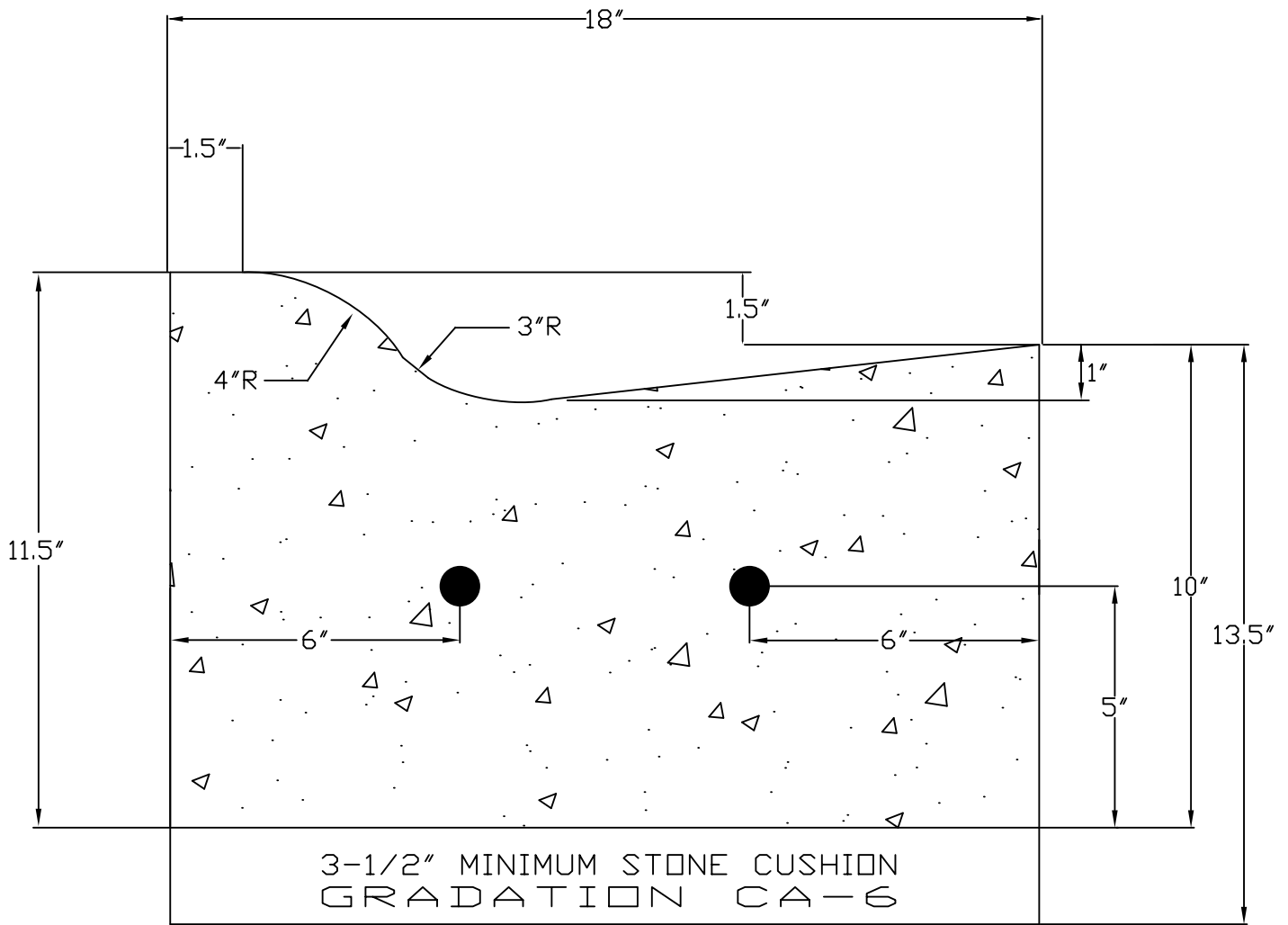

**NOTES:**

1. REINFORCEMENT: PROVIDE TWO (2) #4 REINFORCING BARS CONTINUOUS BETWEEN EXPANSION JOINTS, WITH LOCATION SPACING AS INDICATED ABOVE.
2. EXPANSION JOINT: 3/4" THICK BITUMINOUS FILLER MATERIAL- PROVIDE TWO (2) #6 X 24" SMOOTH BARS WITH EXPANSION CAPS AT EACH EXPANSION JOINT. INSTALL AT ENDS OF ALL RADII AND NO FURTHER THAN SIXTY (60') FEET APART.
3. SAW THREE (3) EQUALLY SPACED CONTRACTION JOINTS AT TWENTY (20') FEET INTERVALS BETWEEN EXPANSION JOINTS. CONTRACTION JOINTS SHALL BE SAW-CUT IN THE UPPER ONE-THIRD OF CURB AND GUTTER WITHIN 3 DAYS OF PLACEMENT.
4. COST OF BARS SHALL BE INCLUDED IN THE UNIT PRICE (PER LINEAL FOOT) FOR CURB AND GUTTER.

CURB AND GUTTER DETAIL (RESIDENTIAL)		
CURB.DWG	<b>STREET &amp; PAVEMENT</b>	DATE:
DRAWN BY:		REVISED:
Village of <b>ORLAND PARK</b>		REVISED: 2-14-08 rjr
Engineering Department		REVISED: 8-27-07 ktl
		DRAWING NO. <b>STR-03</b>





**CLASS C**

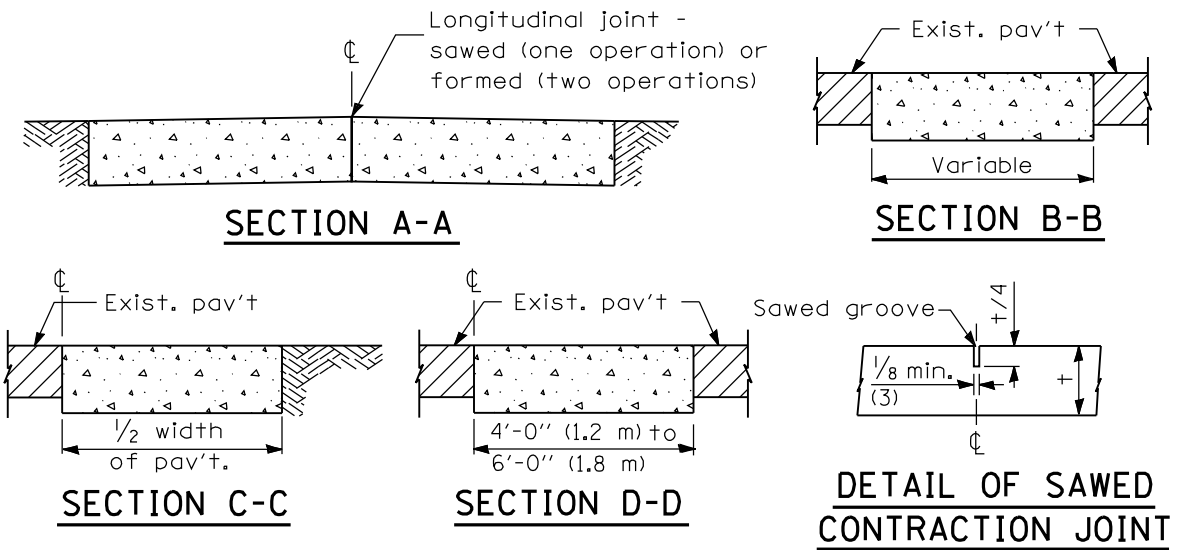
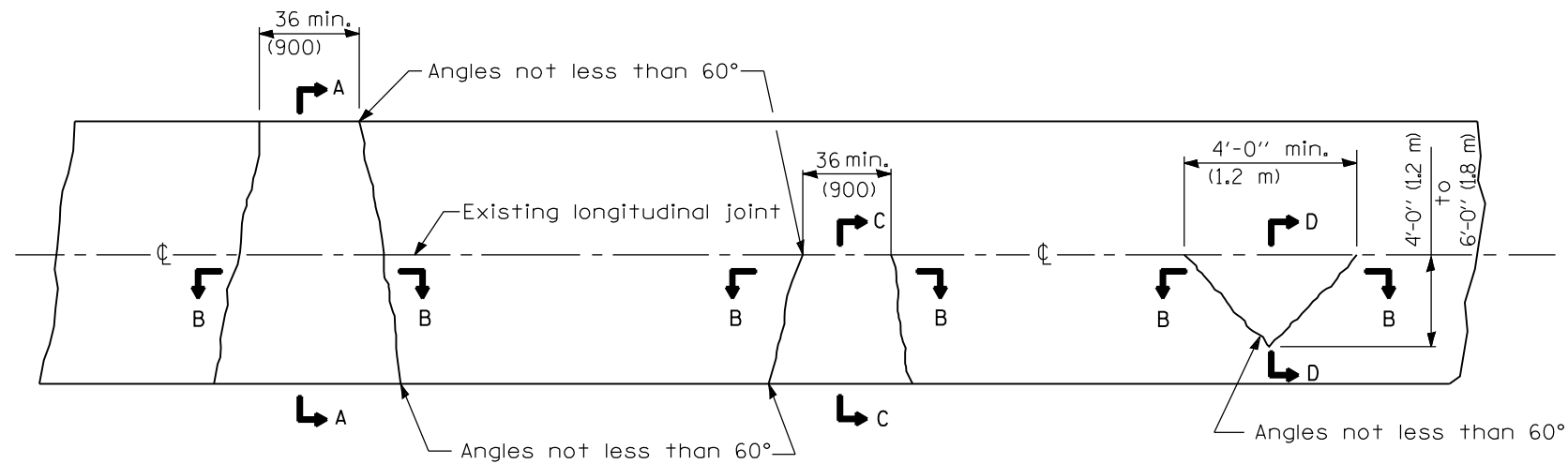

**NOTE**

Longitudinal joints shall be as detailed on Standard 420001, except tie bars are not required for patches 20'-0" (6.0 m) or less in length.

**CLASS D**

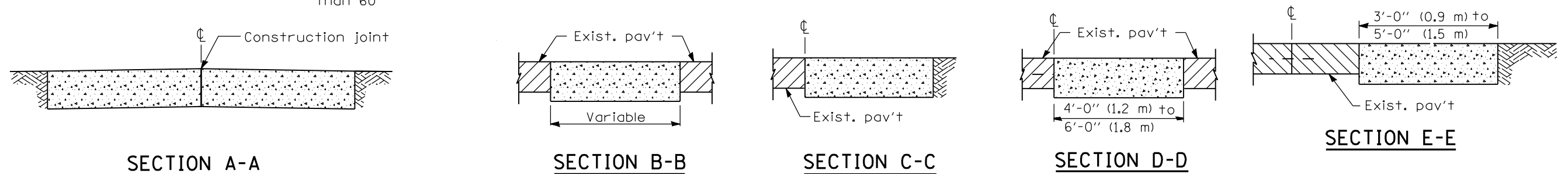
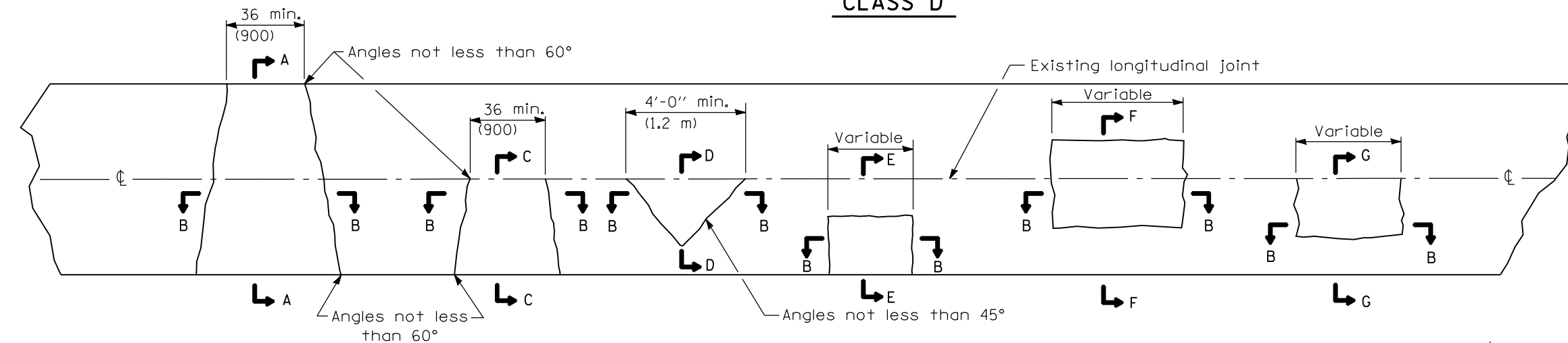

**GENERAL NOTES**

Existing tie bars shall be either cut or removed. Marginal bars shall be cut.

All dimensions are in inches (millimeters) unless otherwise shown.

DATE	REVISIONS
1-1-08	Switched units to English (metric).
1-1-07	Revised Note for Class C patches.

**CLASS C and D PATCHES**

**STANDARD 442201-03**

Illinois Department of Transportation  
 PASSED January 1, 2008  
 ENGINEER OF POLICY AND PROCEDURES  
 APPROVED January 1, 2008  
 ENGINEER OF DESIGN AND ENVIRONMENT

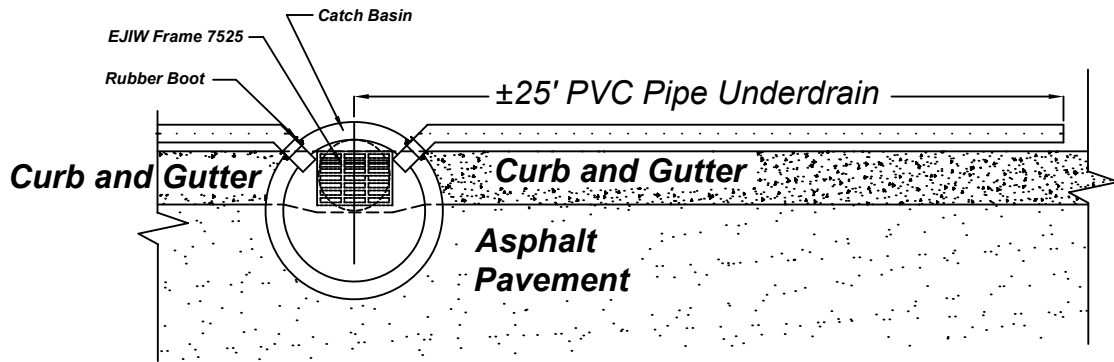

PLAN VIEW

SCALE: N.T.S.

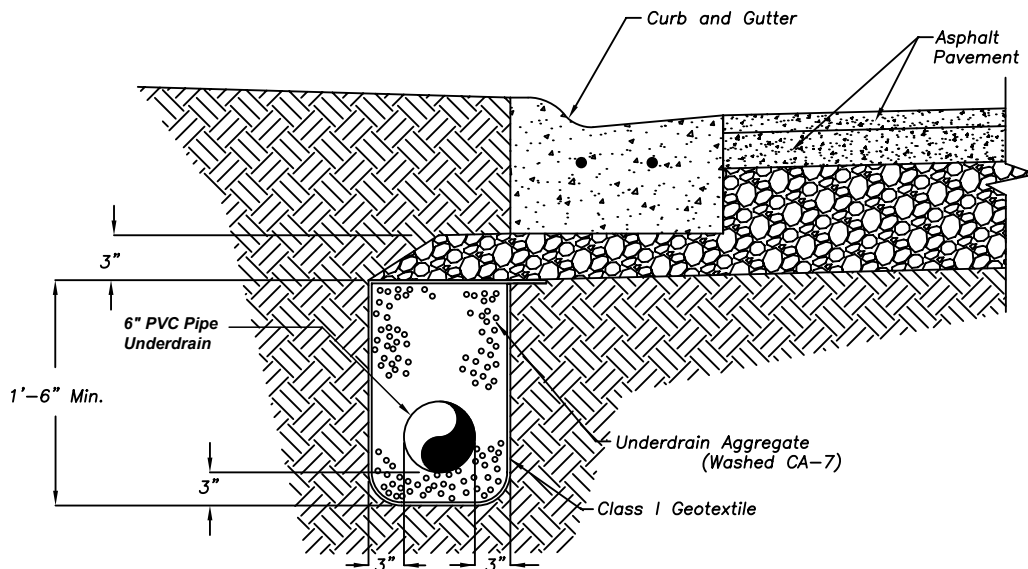

PIPE UNDERDRAIN BEHIND CURB

SCALE: N.T.S.

Underdrain Notes:

1. The installation of the underdrains shall conform to section 601.04 of the Illinois Department of Transportation Standard Specifications for Road and Bridge Construction.
2. Pipe material shall be 6" perforated PVC, per article 1040.03 of the IDOT Standard Specifications.
3. The underdrains shall be installed with the drain perforations down. All underdrains shall be held in the center of the trench by mechanical means while placing compacted trench backfill of washed CA-7.
4. After the underdrain pipe is installed, the geotextile shall be folded over the underdrain aggregate and overlapped a minimum of 12".
5. The underdrains shall have watertight joints, and be tied into the nearest storm sewer inlet. The connection to the inlet structure shall conform to ASTM C-923.

CURB UNDERDRAIN DETAIL – Back of Curb		
Underdrain-bc.dwg	<b>STREET &amp; PAVEMENT</b>	DATE: 11/20/2006
DRAWN BY:		REVISED:
<b>Village of ORLAND PARK</b>		REVISED:
Public Works Department		REVISED: 2-14-08 rjr
		DRAWING NO. <b>STR-20</b>

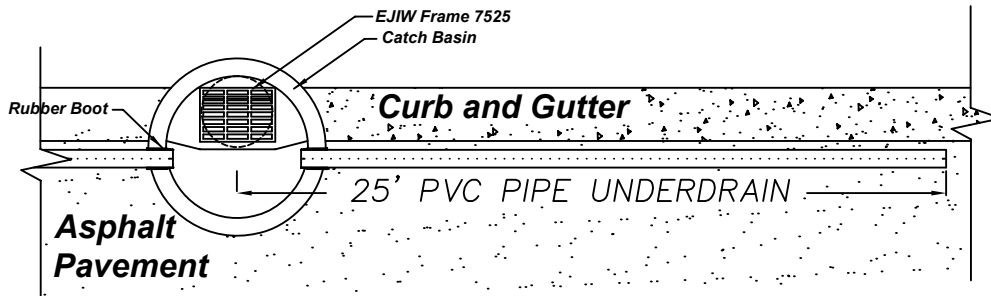

PLAN VIEW

SCALE: N.T.S.

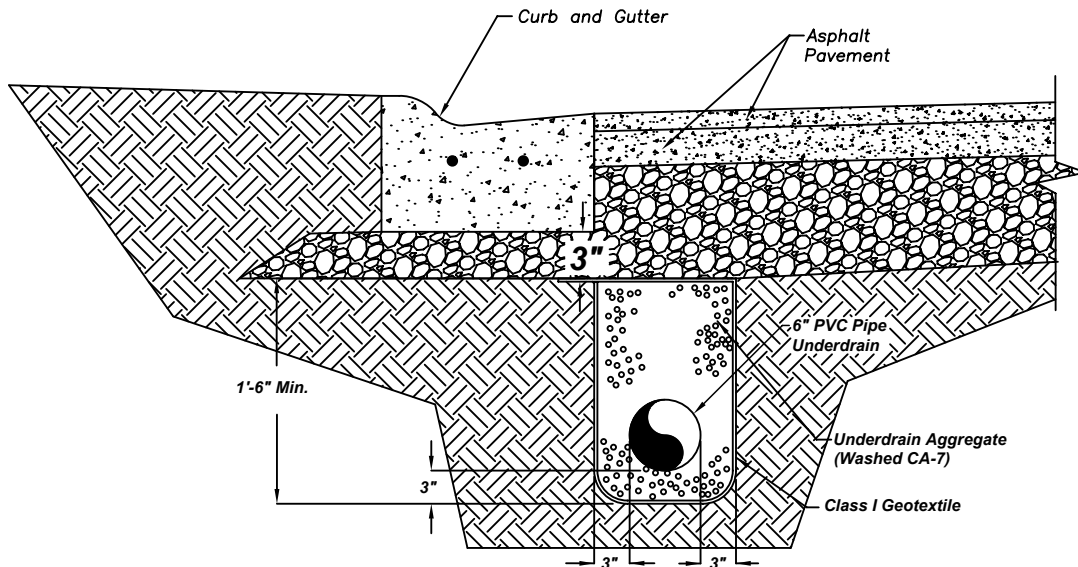

PIPE UNDERDRAIN FRONT OF CURB

SCALE: N.T.S.

Underdrain Notes:

1. The installation of the underdrains shall conform to section 601.04 of the Illinois Department of Transportation Standard Specifications for Road and Bridge Construction.
2. Pipe material shall be 6" perforated PVC, per article 1040.03 of the IDOT Standard Specifications.
3. The underdrains shall be installed just below the bottom of the existing curb (or as necessary to provide positive flow), with the drain perforations down. All underdrains shall be held in the center of the trench by mechanical means while placing compacted trench backfill of washed CA-7.
4. After the underdrain pipe is installed, the geotextile shall be folded over the underdrain aggregate and overlapped a minimum of 12".
5. The underdrains shall have watertight joints, and be tied into the nearest storm sewer inlet, as designated by the Village.

<b>CURB UNDERDRAIN DETAIL – Front of Curb</b>		
Underdrain-fe.dwg	<b>STREET &amp; PAVEMENT</b>	DATE: 11/15/2006
DRAWN BY:		REVISED:
<b>Village of ORLAND PARK</b>		REVISED:
<b>Public Works Department</b>		REVISED: 2-14-08 rjr
		DRAWING NO. STR-____

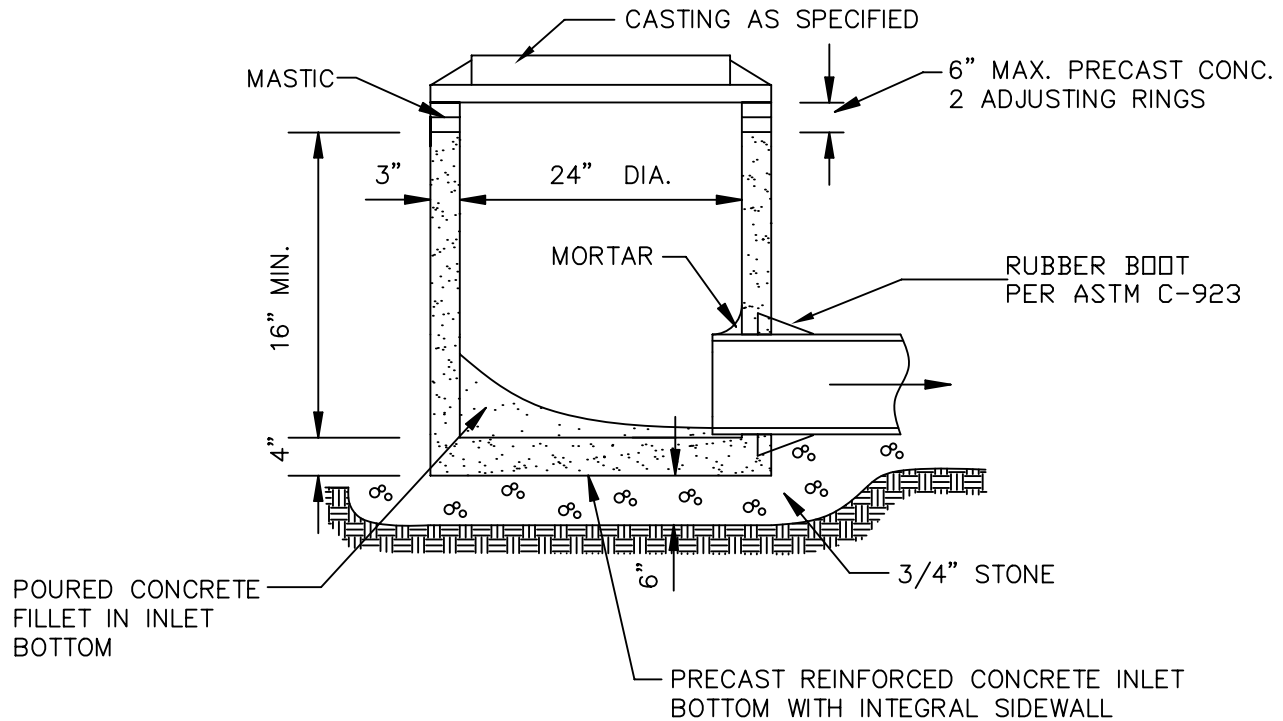

**NOTES:**

1. Adjustment: Any structure located within pavement shall require the use of at least one (1) rubber adjustment riser, Infra-Riser brand or approved equal, and, if necessary, said riser shall be of the tapered type in order to match the proposed grade of the roadway. No more than two (2) precast concrete adjusting rings with six (6) inch maximum height adjustment shall be allowed. Adjustments within pavement that are less than three (3) inches in height shall consist of only rubber adjustment riser(s). The minimum thickness of a rubber adjustment riser shall be one (1) inch. Adjustments within pavement greater than three (3) inches in height shall use a minimum three (3) inch precast concrete riser for the lower riser, and the final riser shall be of the rubber type.
2. Pipe and frame seals: All pipe connection openings shall be precast with resilient rubber water tight pipe to manhole sleeves or seals conforming to ASTM C-923. Adapter chimney seal with twelve (12) inch sleeve type shall extend from the manhole cone to the manhole frame for all structures in the right-of-way.
3. Sealing: All non-rubber mating surfaces, exterior joints of frames, adjustment riser(s), flat slab top or cone section (if applicable) and structure section shall be sealed with a uniform application of bituminous mastic sealant. The mating surfaces of all rubber Adjustment risers shall be sealed with the manufacturer's recommended sealant for rubber adjustment risers. If multiple adjustment risers are required, a continuous application of sealant shall be applied between each unit. Interior surfaces shall be sealed with concrete mortar or epoxy mortar. Concrete mortar or epoxy mortar will not be used on mating surfaces as a sealant between adjustment risers, structure sections or frames
4. All bottom sections shall be monolithically precast including bases and invert flowlines.
5. Provide CA-6 aggregate backfill around inlet to subgrade elevation in paved areas.for subgrade.

<b>INLET TYPE A</b>		
INLET_A.DWG	<b>STORM SEWER IMPROVEMENT</b>	DATE:
DRAWN BY:		REVISED:
<b>Village of ORLAND PARK</b>		REVISED:
<b>Engineering Department</b>		DRAWING NO. <b>STS-05</b>

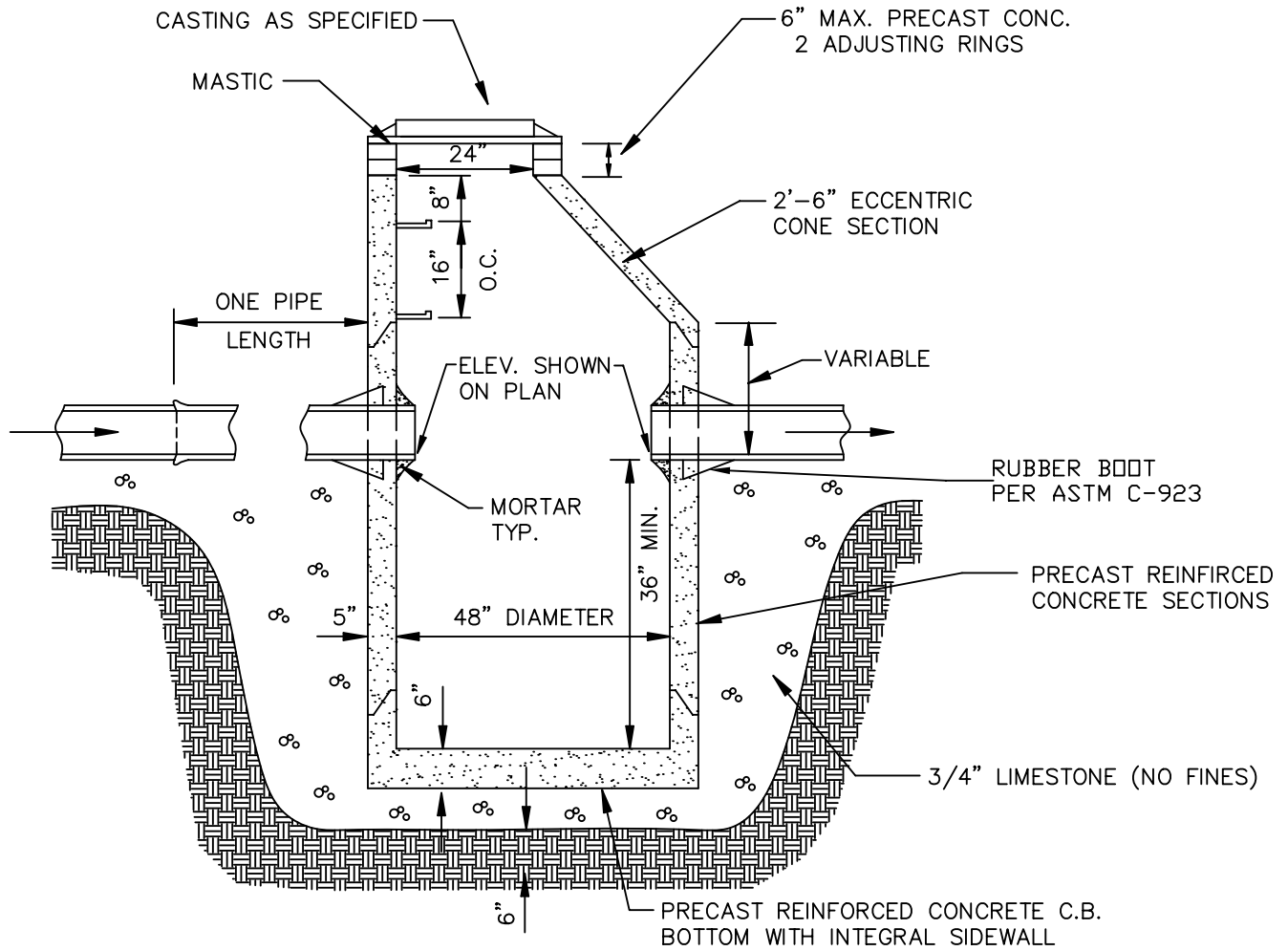

**NOTES:**

1. Adjustment: Any structure located within pavement shall require the use of at least one (1) rubber adjustment riser, Infra-Riser brand or approved equal, and, if necessary, said riser shall be of the tapered type in order to match the proposed grade of the roadway. No more than two (2) precast concrete adjusting rings with six (6) inch maximum height adjustment shall be allowed. Adjustments within pavement that are less than three (3) inches in height shall consist of only rubber adjustment riser(s). The minimum thickness of a rubber adjustment riser shall be one (1) inch. Adjustments within pavement greater than three (3) inches in height shall use a minimum three (3) inch precast concrete riser for the lower riser, and the final riser shall be of the rubber type.
2. Pipe and frame seals: All pipe connection openings shall be precast with resilient rubber water tight pipe to manhole sleeves or seals conforming to ASTM C-923. Adapter chimney seal with twelve (12) inch sleeve type shall extend from the manhole cone to the manhole frame for all structures in the right-of-way.
3. Sealing: All mating surfaces of adjustment riser(s), structure sections, and frames shall be sealed with a mastic sealant. No concrete mortar or epoxy shall be allowed as a sealant for adjustment risers, structure sections or frames. If multiple adjustment risers are required, a continuous application of sealant shall be applied between each unit.
4. All bottom sections shall be monolithically precast including bases and invert flowlines.
5. Provide CA-6 aggregate backfill around catch basin to subgrade elevation in paved areas for subgrade.

<b>CATCHBASIN TYPE A</b>		
CBASIN_A.DWG	<b>STORM SEWER IMPROVEMENT</b>	DATE:
DRAWN BY:		REVISED:
<b>Village of ORLAND PARK</b>		REVISED:
<b>Engineering Department</b>		DRAWING NO. <b>STS-02</b>

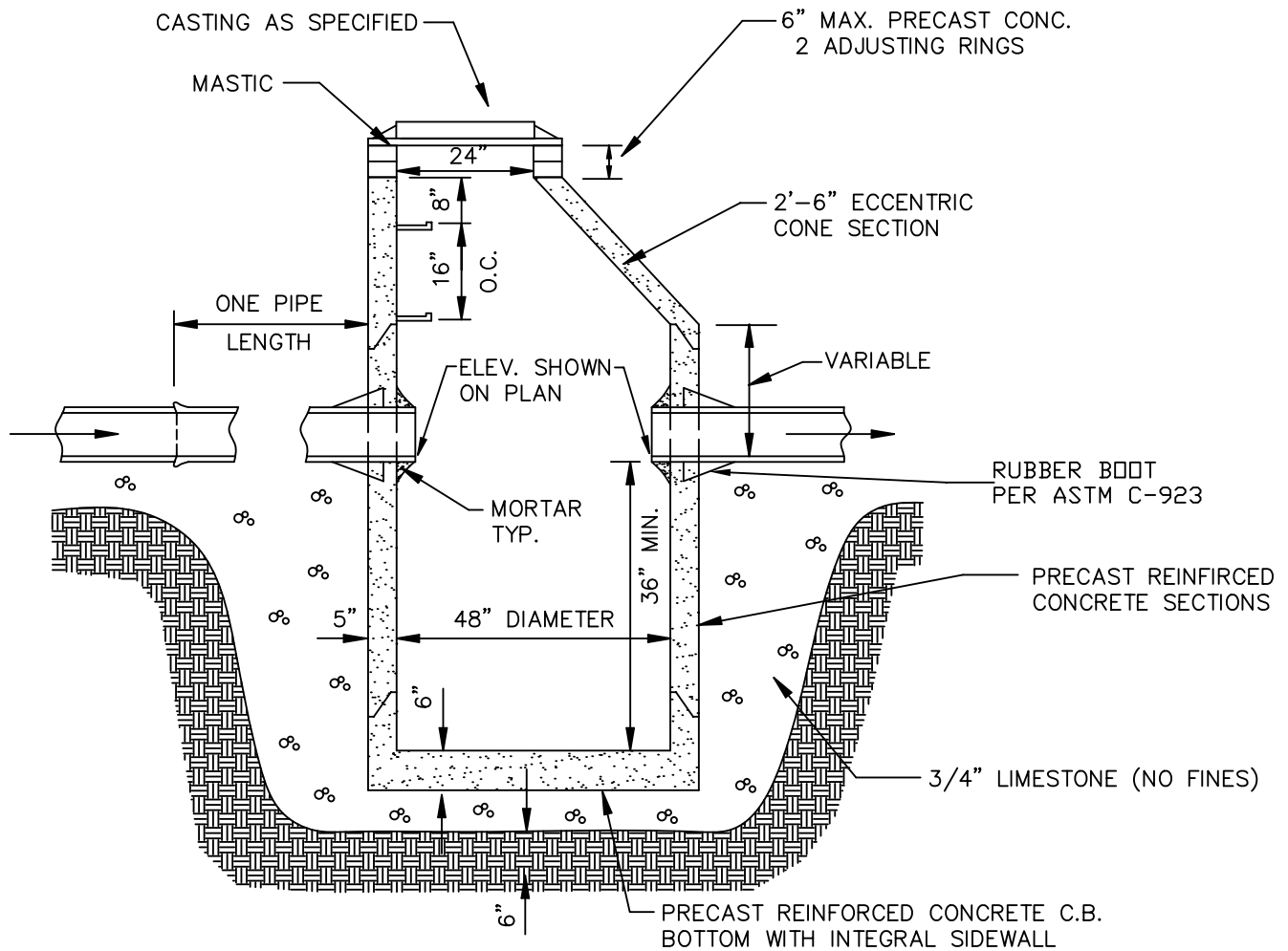

**NOTES:**

1. Adjustment: Any structure located within pavement shall require the use of at least one (1) rubber adjustment riser, Infra-Riser brand or approved equal, and, if necessary, said riser shall be of the tapered type in order to match the proposed grade of the roadway. No more than two (2) precast concrete adjusting rings with six (6) inch maximum height adjustment shall be allowed. Adjustments within pavement that are less than three (3) inches in height shall consist of only rubber adjustment riser(s). The minimum thickness of a rubber adjustment riser shall be one (1) inch. Adjustments within pavement greater than three (3) inches in height shall use a minimum three (3) inch precast concrete riser for the lower riser, and the final riser shall be of the rubber type.
2. Pipe and frame seals: All pipe connection openings shall be precast with resilient rubber water tight pipe to manhole sleeves or seals conforming to ASTM C-923. Adapter chimney seal with twelve (12) inch sleeve type shall extend from the manhole cone to the manhole frame for all structures in the right-of-way.
3. Sealing: All mating surfaces of adjustment riser(s), structure sections, and frames shall be sealed with a mastic sealant. No concrete mortar or epoxy shall be allowed as a sealant for adjustment risers, structure sections or frames. If multiple adjustment risers are required, a continuous application of sealant shall be applied between each unit.
4. All bottom sections shall be monolithically precast including bases and invert flowlines.
5. Provide CA-6 aggregate backfill around catch basin to subgrade elevation in paved areas for subgrade.

<b>CATCHBASIN TYPE A</b>		
CBASIN_A.DWG	<b>STORM SEWER IMPROVEMENT</b>	DATE:
DRAWN BY:		REVISED:
<b>Village of ORLAND PARK</b>		REVISED:
<b>Engineering Department</b>		DRAWING NO. <b>STS-02</b>

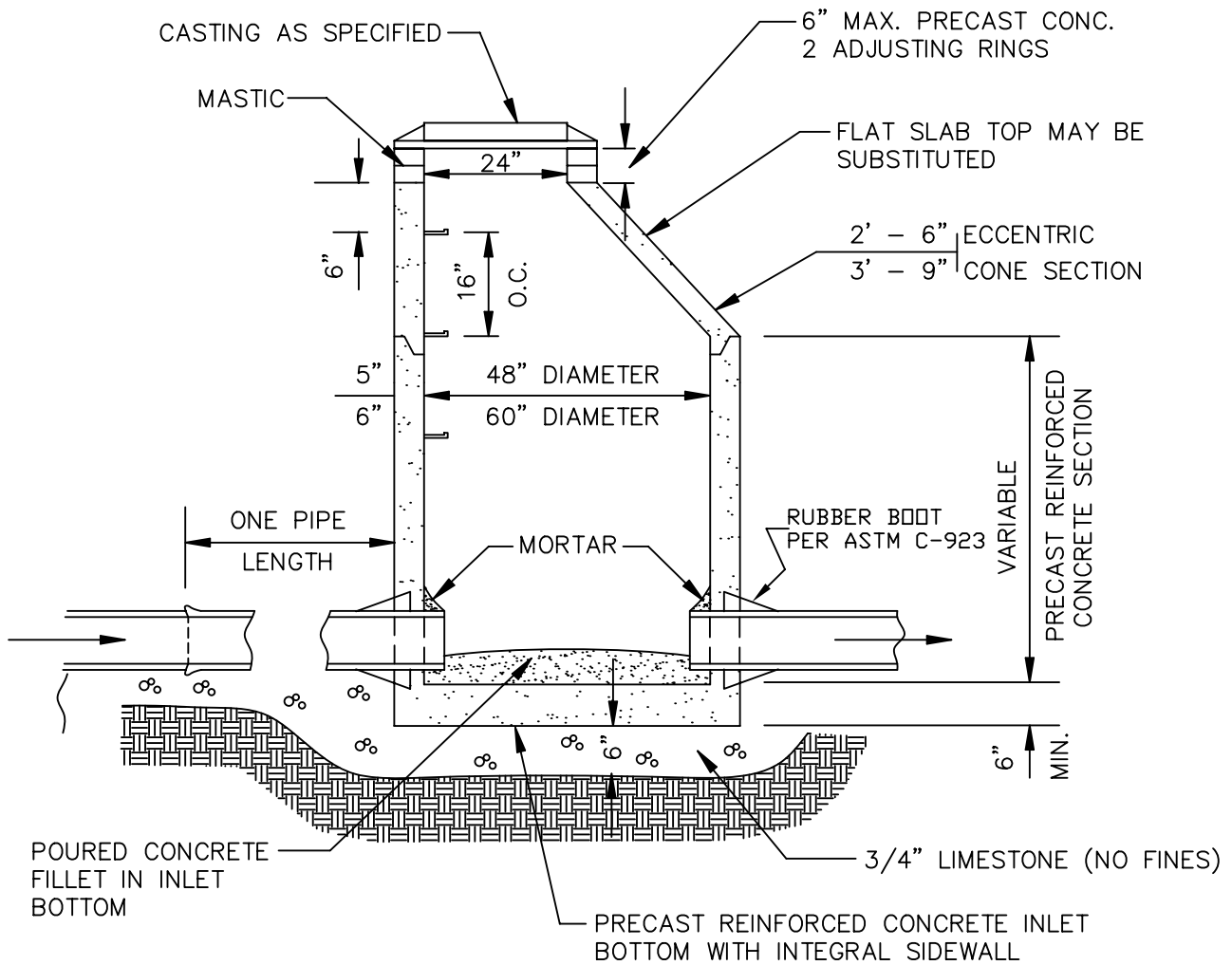

**NOTES:**

1. Adjustment: Any structure located within pavement shall require the use of at least one (1) rubber adjustment riser, Infra-Riser brand or approved equal, and, if necessary, said riser shall be of the tapered type in order to match the proposed grade of the roadway. No more than two (2) precast concrete adjusting rings with six (6) inch maximum height adjustment shall be allowed. Adjustments within pavement that are less than three (3) inches in height shall consist of only rubber adjustment riser(s). The minimum thickness of a rubber adjustment riser shall be one (1) inch. Adjustments within pavement greater than three (3) inches in height shall use a minimum three (3) inch precast concrete riser for the lower riser, and the final riser shall be of the rubber type.
2. Pipe and frame seals: All pipe connection openings shall be precast with resilient rubber water tight pipe to manhole sleeves or seals conforming to ASTM C-923. Adapter chimney seal with twelve (12) inch sleeve type shall extend from the manhole cone to the manhole frame for all structures in the right-of-way.
3. Sealing: All mating surfaces of adjustment riser(s), structure sections, and frames shall be sealed with a mastic sealant. No concrete mortar or epoxy shall be allowed as a sealant for adjustment risers, structure sections or frames. If multiple adjustment risers are required, a continuous application of sealant shall be applied between each unit.
4. All bottom sections shall be monolithically precast including bases and invert flowlines.
5. Provide CA-6 aggregate backfill around manhole to subgrade elevation in paved areas for subgrade.

STORM MANHOLE		
STORMMH.DWG	<b>STORM SEWER IMPROVEMENT</b>	DATE:
DRAWN BY:		REVISED:
Village of <b>ORLAND PARK</b>		REVISED:
Engineering Department		DRAWING NO. <b>STS-01</b>



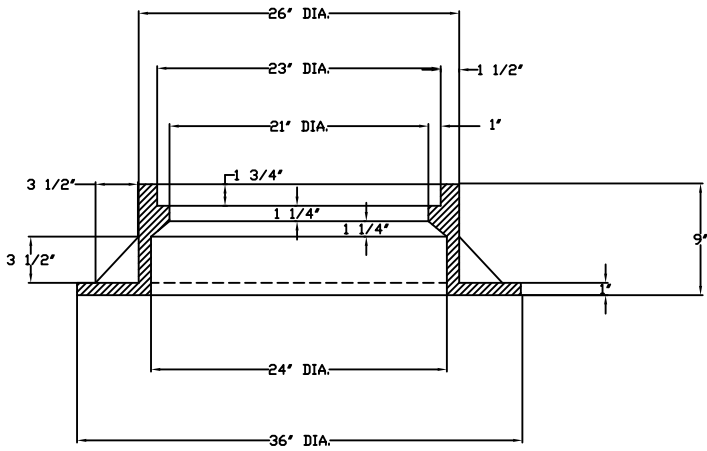
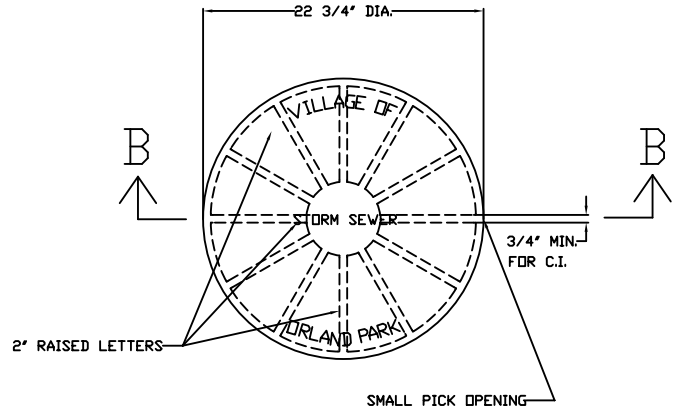
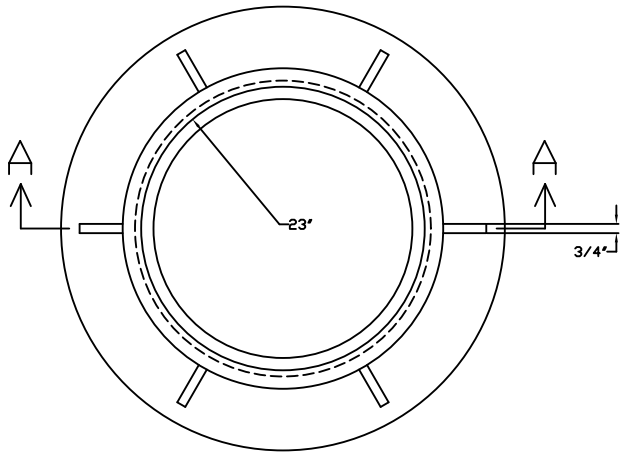

SECTION A-A  
CAST FRAME

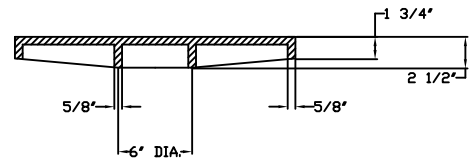

SECTION B-B  
CAST CLOSED LID

- NOTES:
1. DUCTILE IRON CASTINGS SHALL BE GRADE 60-40-18 AND SHALL BE TESTED IN ACCORDANCE WITH FEDERAL SPECIFICATIONS.
  2. ALL LIDS AND COVERS SHALL BE MACHINED.
  3. THE MANHOLE COVERS SHALL HAVE RAISED LETTERS AS SHOWN.
  4. ALTERNATIVE TO DUCTILE IRON LID, GRAY IRON LID MAY BE USED.
  5. MINIMUM WEIGHTS FOR CASTINGS AS SHOWN.
  6. CASTINGS SHALL BE EAST JORDAN IRON WORKS 1050Z1 FRAME AND 1020A COVER.

<b>STORM SEWER FRAME &amp; COVER</b>		
FRAME&CO.DWG	<b>STORM SEWER IMPROVEMENT</b>	DATE:
DRAWN BY:		REVISED:
<b>Village of ORLAND PARK</b>		REVISED:
<b>Engineering Department</b>		DRAWING NO. <b>STS-14</b>

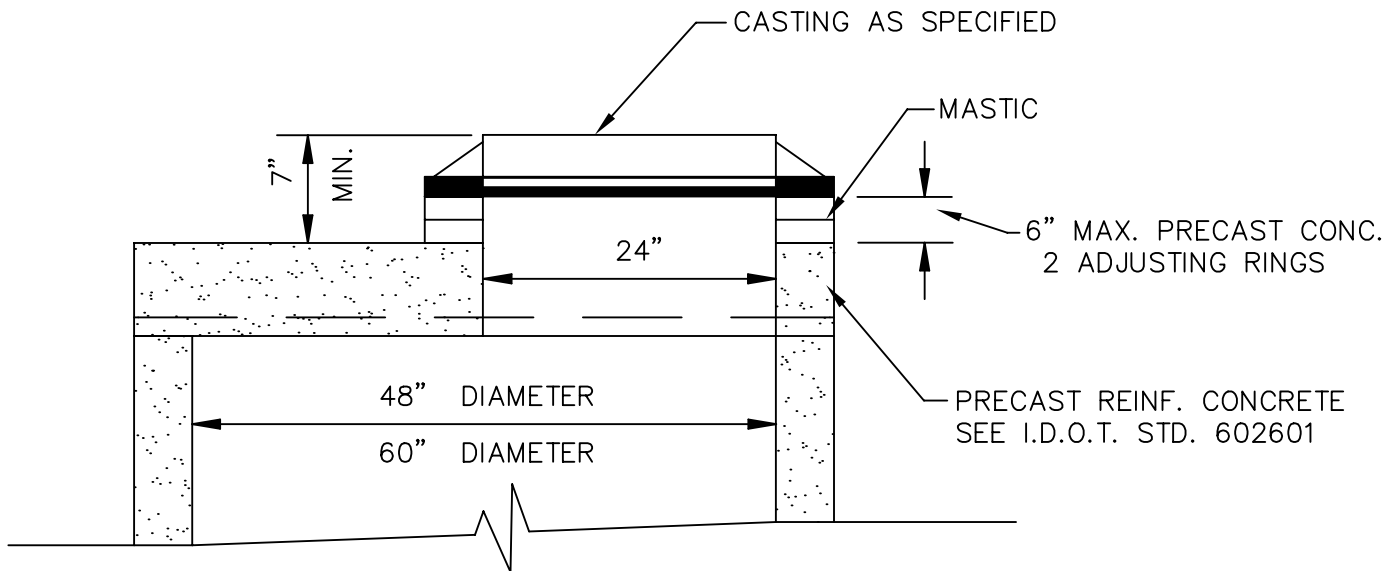

NOTES:

1. Adjustment: Any structure located within pavement shall require the use of at least one (1) rubber adjustment riser, Infra-Riser brand or approved equal, and, if necessary, said riser shall be of the tapered type in order to match the proposed grade of the roadway. No more than two (2) precast concrete adjusting rings with six (6) inch maximum height adjustment shall be allowed. Adjustments within pavement that are less than three (3) inches in height shall consist of only rubber adjustment riser(s). The minimum thickness of a rubber adjustment riser shall be one (1) inch. Adjustments within pavement greater than three (3) inches in height shall use a minimum three (3) inch precast concrete riser for the lower riser, and the final riser shall be of the rubber type.
2. Sealing: All non-rubber mating surfaces, exterior joints of frames, adjustment riser(s), flat slab top or cone section (if applicable) and structure section shall be sealed with a uniform application of bituminous mastic sealant. The mating surfaces of all rubber adjustment risers shall be sealed with the manufacturer's recommended sealant for rubber adjustment risers. If multiple adjustment risers are required, a continuous application of sealant shall be applied between each unit. Interior surfaces shall be sealed with concrete mortar or epoxy mortar. Concrete mortar or epoxy mortar will not be used on mating surfaces as a sealant between adjustment risers, structure sections or frames.

<b>FLAT SLAB TOP</b>		
FLTSLAB.DWG	<b>STORM SEWER IMPROVEMENT</b>	DATE:
DRAWN BY:		REVISED:
<b>Village of ORLAND PARK</b>		REVISED:
<b>Engineering Department</b>		REVISED:
		DRAWING NO. <b>STS-06</b>

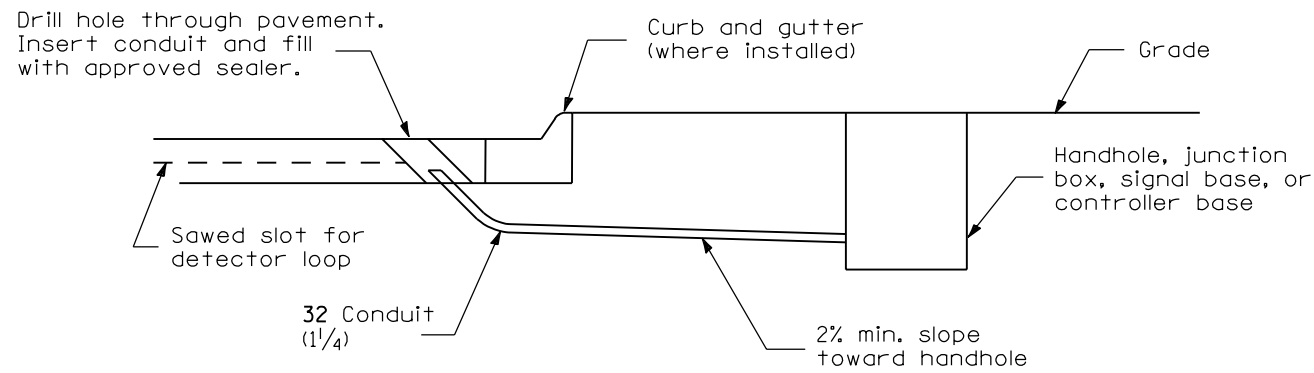

**DETECTOR LOOP LEAD-IN**

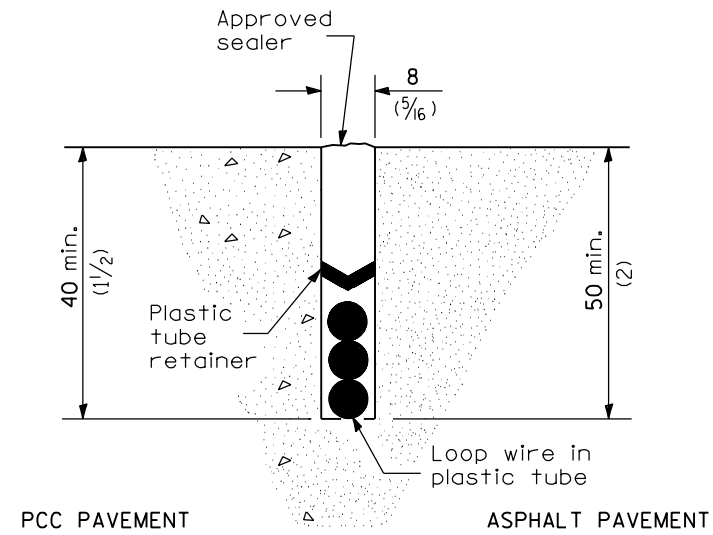

**DETECTOR LOOP INSTALLATION**

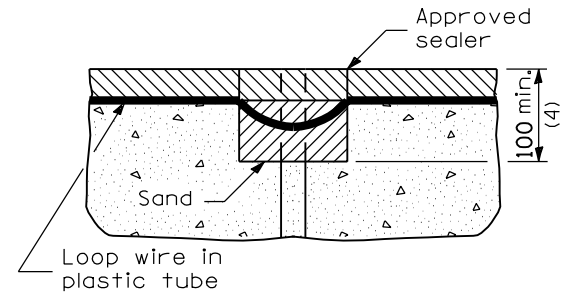
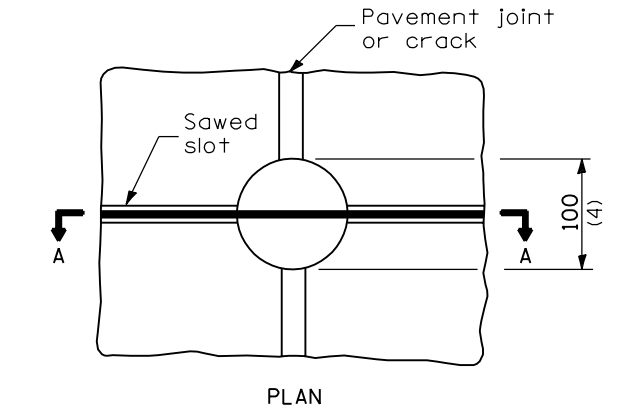

**SECTION A-A**

**NOTE**

Loop wire shall follow saw cut to bottom, forming slack section at joint.

**DETECTOR LOOP AT PAVEMENT JOINT OR PAVEMENT CRACK**

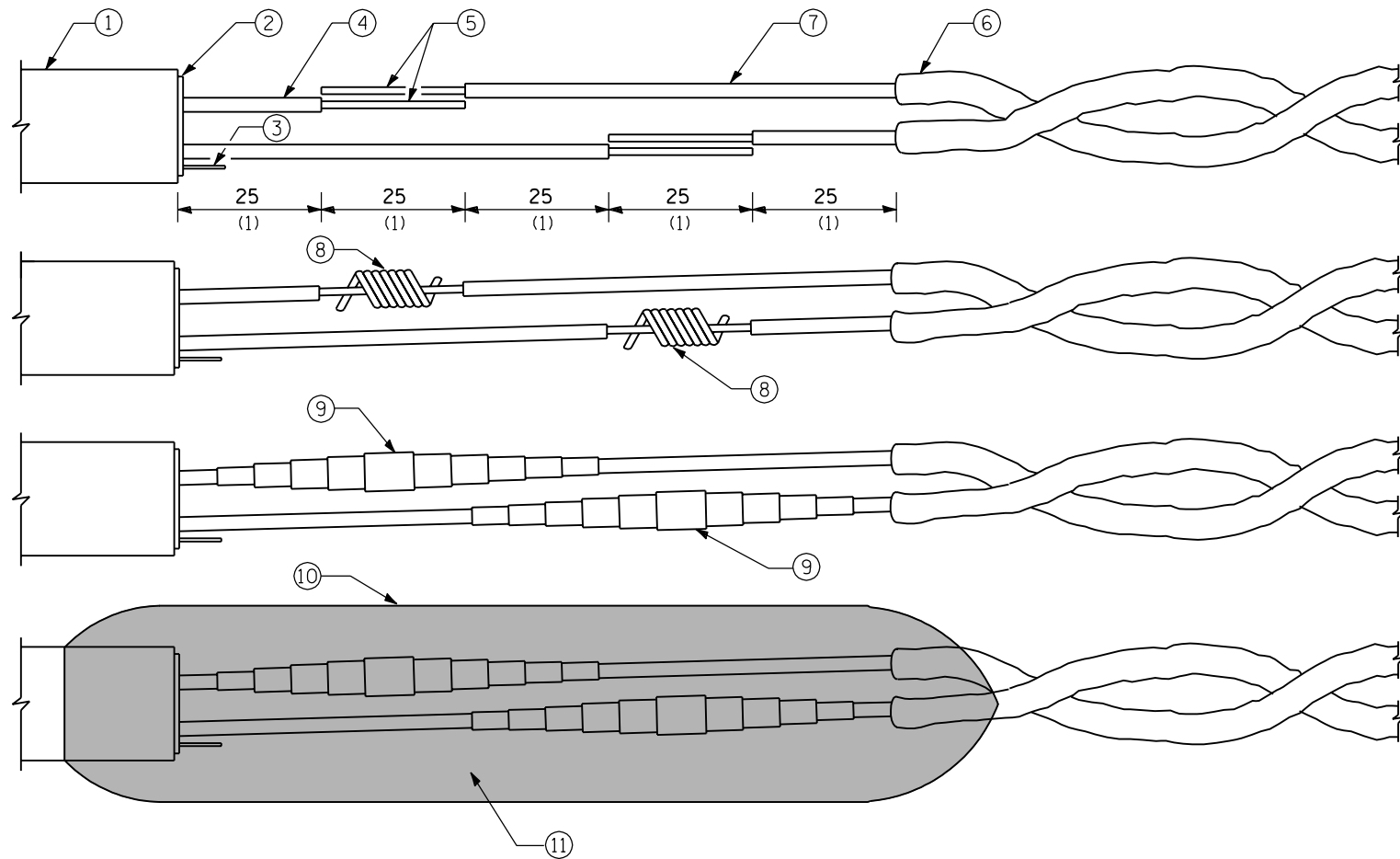

**LOOP WIRE AND LEAD-IN CABLE SPLICE**

- ① = Lead-in cable (single pair or multipair)
- ② = Lead-in cable shield
- ③ = Lead-in cable shield drain-wire
- ④ = Lead-in cable insulated conductor
- ⑤ = Bare conductor
- ⑥ = Loop wire in tube
- ⑦ = Loop wire insulated conductor
- ⑧ = Twisted and resin soldered conductor
- ⑨ = Electrical tape insulated splice
- ⑩ = Rigid mold
- ⑪ = Waterproof and dielectric resin

All dimensions are in millimeters (inches) unless otherwise shown.

Illinois Department of Transportation

APPROVED January 1, 2002  
*[Signature]*  
 ENGINEER OF OPERATIONS

APPROVED January 1, 2002  
*[Signature]*  
 ENGINEER OF DESIGN AND ENVIRONMENT

ISSUED 1-1-02

DATE	REVISIONS
1-1-02	Renum. Standard 846001.
1-1-97	Renum. Standard 2370-2.

**DETECTOR LOOP INSTALLATIONS**

**STANDARD 886001**

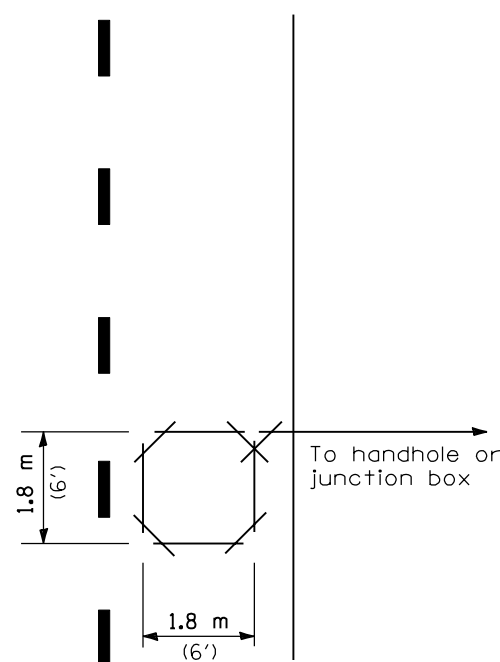

FOR POINT DETECTION  
SHORT LOOP

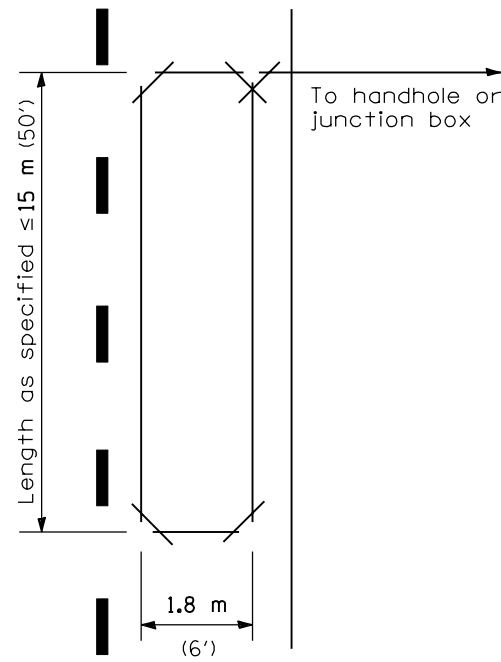

FOR PRESENCE DETECTION  
LONG LOOP

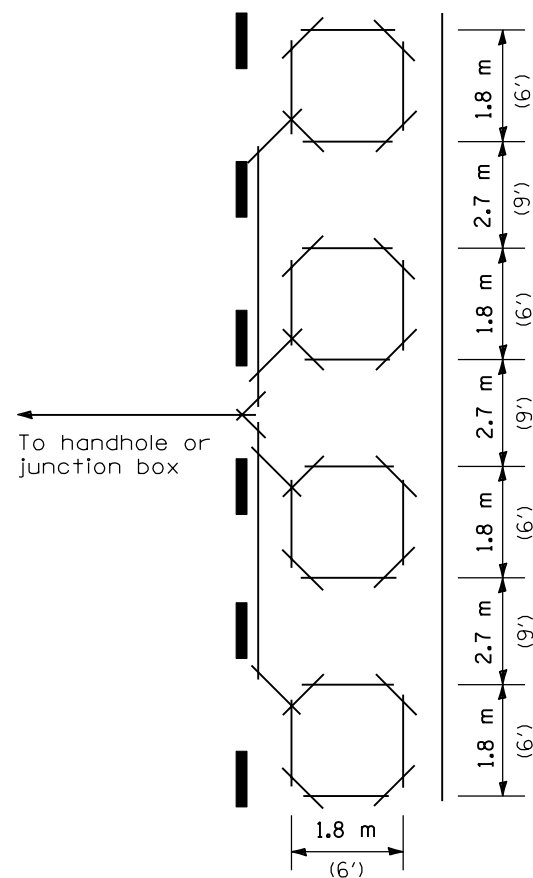

FOR PRESENCE DETECTION  
MULTIPLE LOOP IN SERIES

**SLOT PLAN**

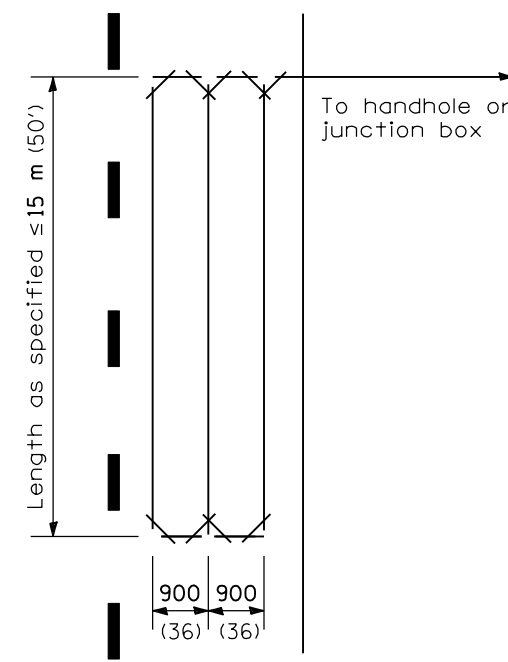

FOR PRESENCE DETECTION  
QUADRUPOLE LOOP

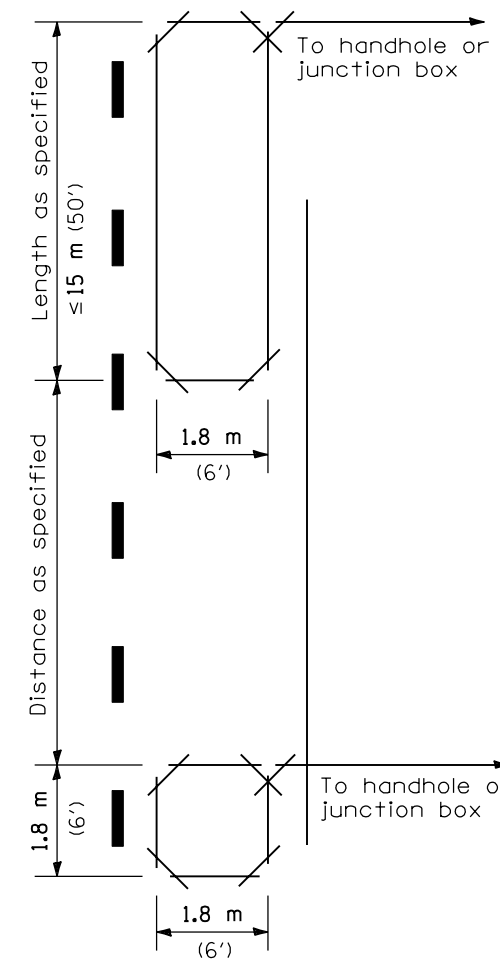

FOR EXTENDED-CALL DETECTION

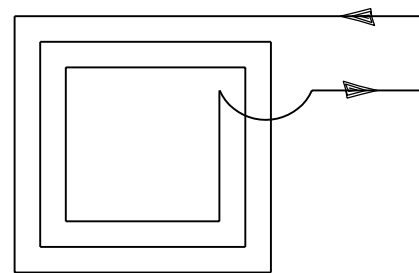

SHORT LOOP

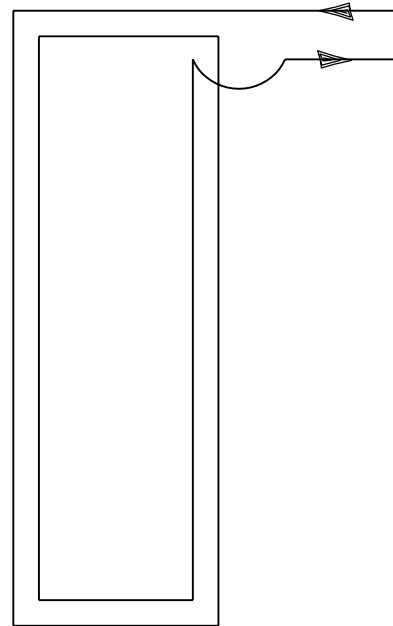

LONG LOOP

**WIRING DIAGRAM**

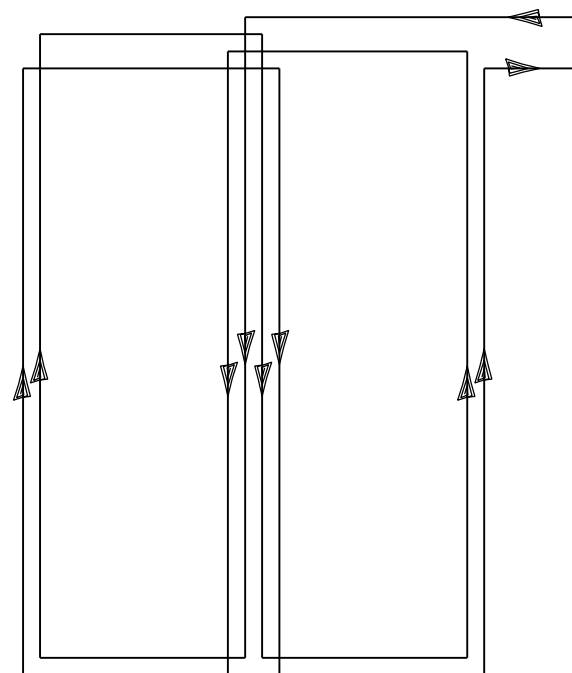

QUADRUPOLE LOOP

All dimensions are in millimeters (inches) unless otherwise shown.

Illinois Department of Transportation	
APPROVED	January 1, 2002
<i>[Signature]</i>	
ENGINEER OF OPERATIONS	
APPROVED	January 1, 2002
<i>[Signature]</i>	
ENGINEER OF DESIGN AND ENVIRONMENT	
ISSUED	1-1-02

DATE	REVISIONS
1-1-02	Renum. Standard 846006.
1-1-97	Renum. Standard 2394-1.

**TYPICAL LAYOUTS  
FOR DETECTION LOOPS**

**STANDARD 886006**

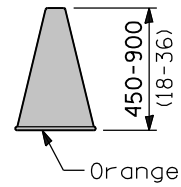

**CONE**

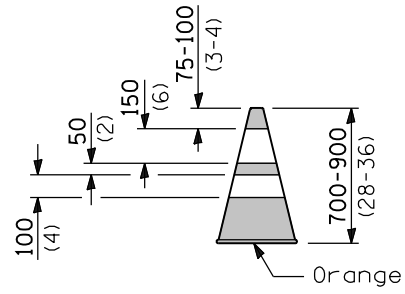

**REFLECTORIZED CONE**

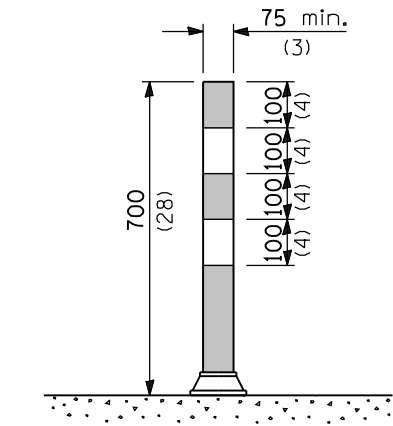

**FLEXIBLE DELINEATOR**

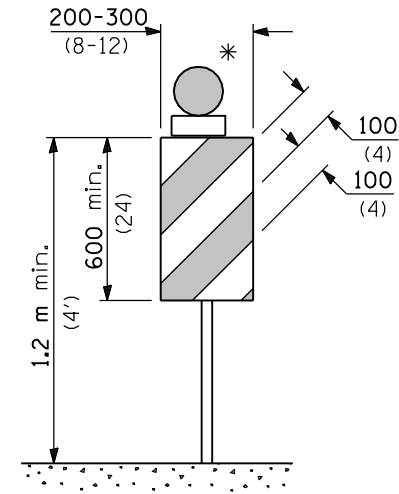

**VERTICAL PANEL  
POST MOUNTED**

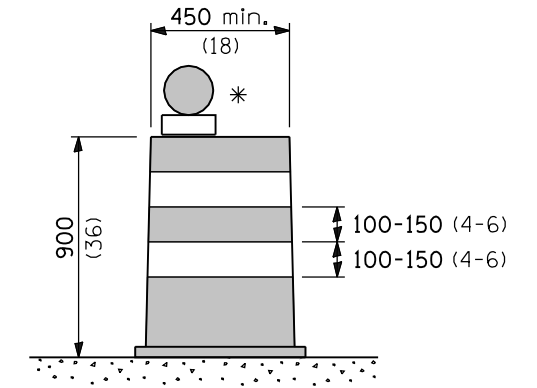

**DRUM**

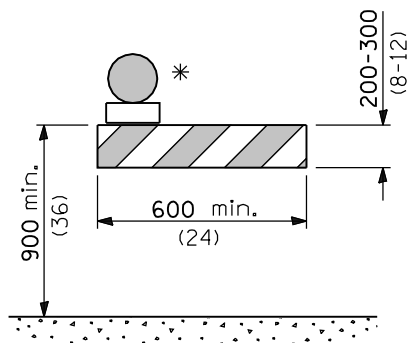

**TYPE I BARRICADE**

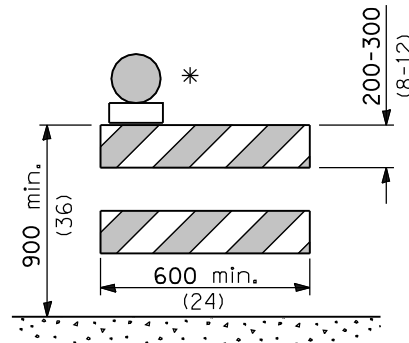

**TYPE II BARRICADE**

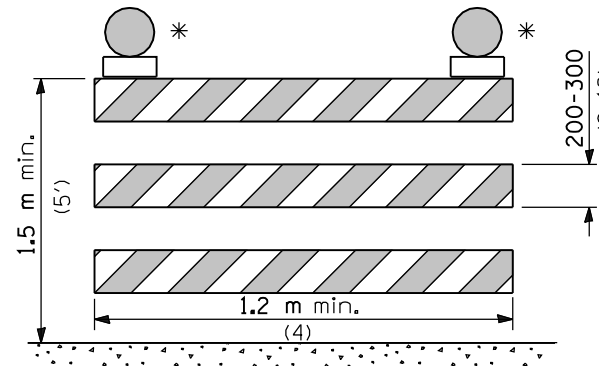

**TYPE III BARRICADE**

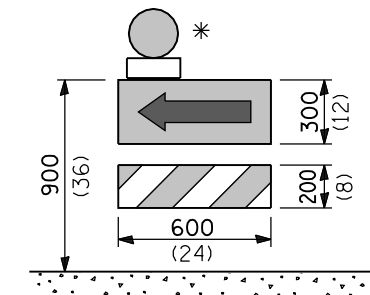

**DIRECTION INDICATOR  
BARRICADE**

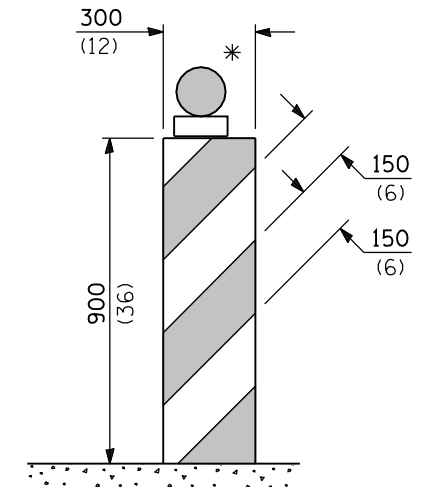

**VERTICAL BARRICADE**

\* Warning lights (if required)

**GENERAL NOTES**

All heights shown shall be measured above the pavement surface.  
All dimensions are in millimeters (inches) unless otherwise shown.

DATE	REVISIONS
1-1-08	Renumbered Standard
	702001-06. Rev. note for temp. signs on Sheet 2.
4-1-06	Revised vert. barricade, post mounted signs, and signs on temp. supports.

**TRAFFIC CONTROL DEVICES**

(Sheet 1 of 3)

**STANDARD 701901**

Illinois Department of Transportation

APPROVED January 1, 2008  
ENGINEER OF OPERATIONS

APPROVED January 1, 2008  
ENGINEER OF DESIGN AND ENVIRONMENT

ISSUED 1-1-07

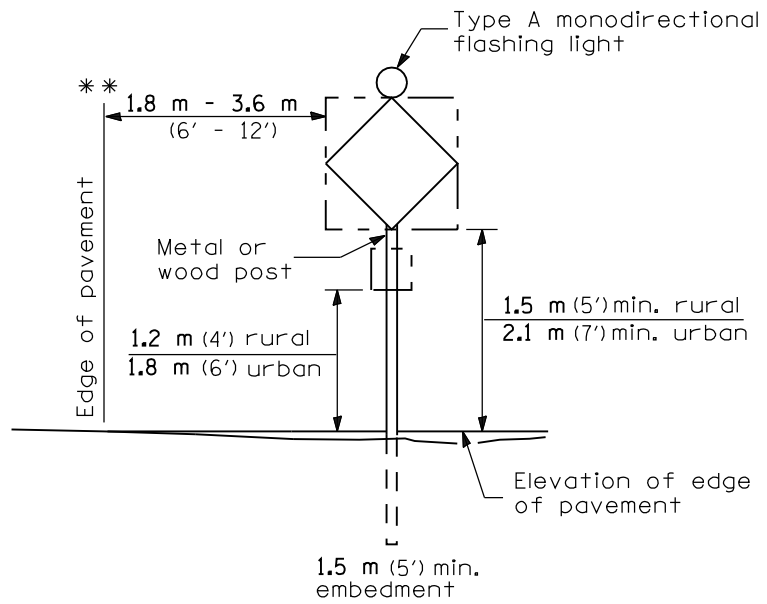

**POST MOUNTED SIGNS**

\*\* When curb or paved shoulder are present this dimension shall be 600 (24) to the face of curb or 1.8 m (6') to the outside edge of the paved shoulder.

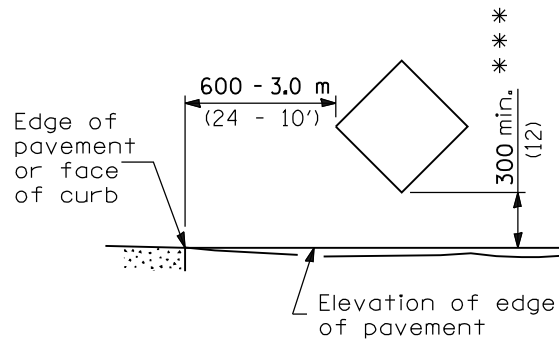

**SIGNS ON TEMPORARY SUPPORTS**

\*\*\* When work operations exceed four days, this dimension shall be 1.5 m (5') min. If located behind other devices, the height shall be sufficient to be seen by motorists.

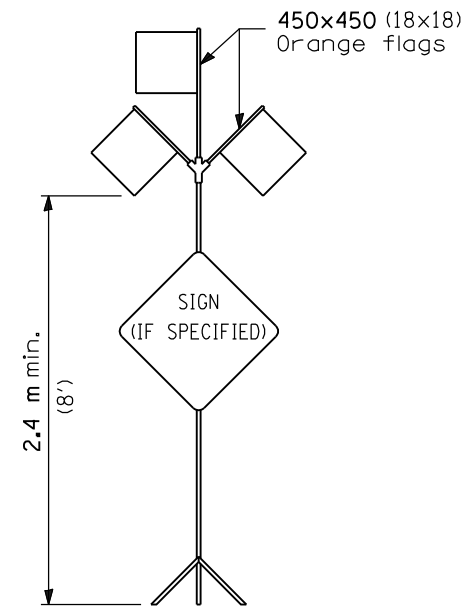

**HIGH LEVEL WARNING DEVICE**



G20-1(0)-6036



G20-2a(0)-6024

This signing is required for all projects 3200 m (2 miles) or more in length.

ROAD CONSTRUCTION NEXT X MILES sign shall be placed 150 m (500') in advance of project limits.

END CONSTRUCTION sign shall be erected at the end of the job unless another job is within 3200 m (2 miles).

Dual sign displays shall be utilized on multi-lane highways.

**WORK LIMIT SIGNING**

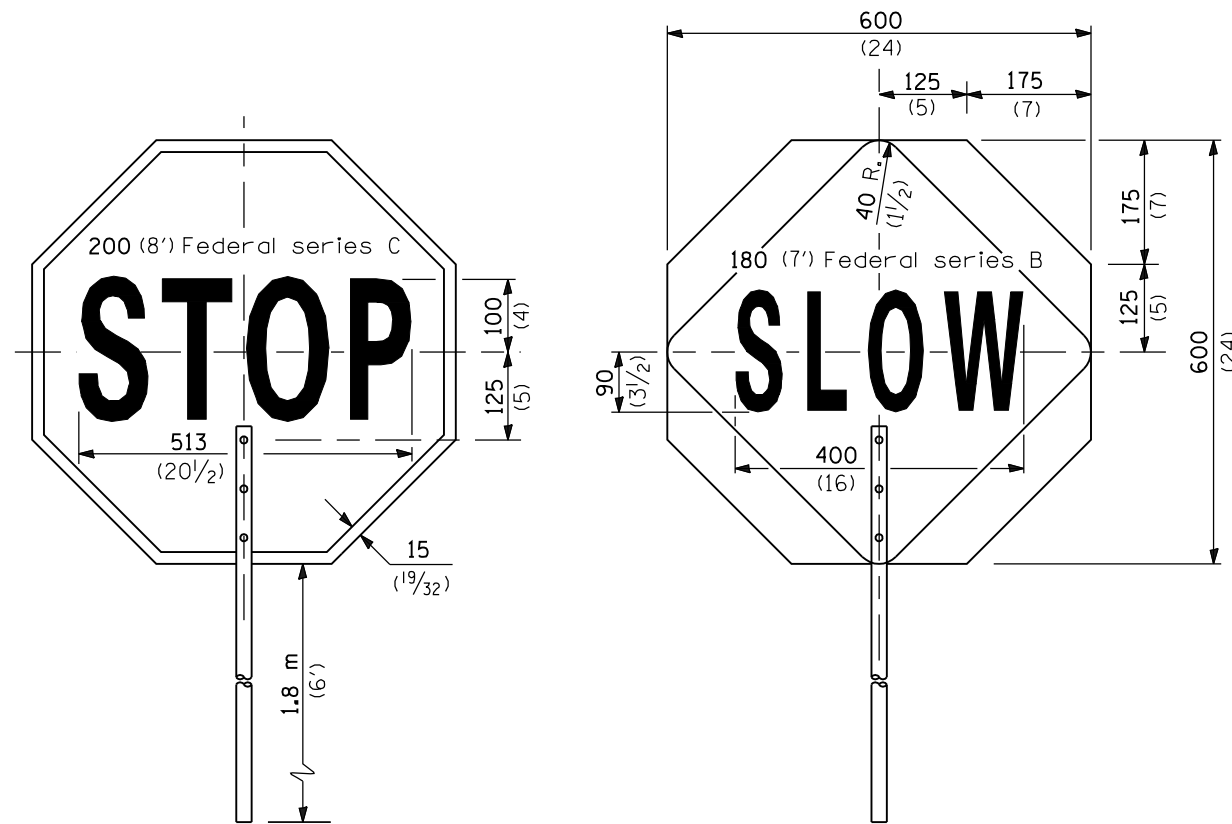

FRONT SIDE

REVERSE SIDE

**FLAGGER TRAFFIC CONTROL SIGN**

All dimensions are in millimeters (inches) unless otherwise shown.

**TRAFFIC CONTROL DEVICES**

(Sheet 2 of 3)

**STANDARD 701901**

Illinois Department of Transportation

APPROVED January 1, 2008  
ENGINEER OF OPERATIONS

APPROVED January 1, 2008  
ENGINEER OF DESIGN AND ENVIRONMENT

ISSUED 1-1-97

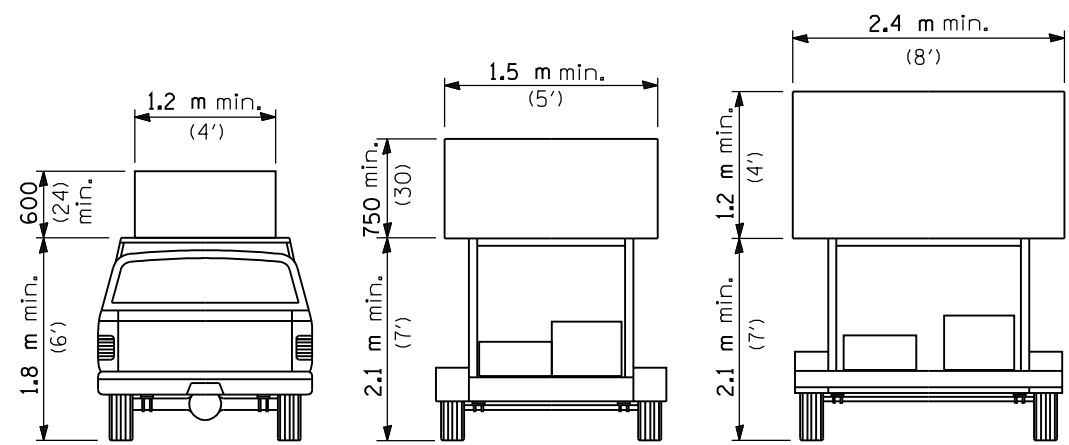

**TYPE A  
ROOF  
MOUNTED**

**TYPE B  
ROOF OR TRAILER  
MOUNTED**

**TYPE C  
TRAILER  
MOUNTED**

**ARROW BOARDS**

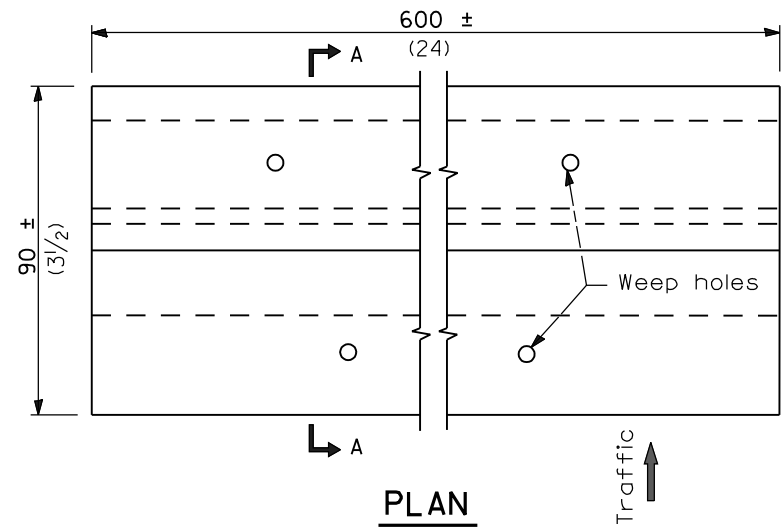

**PLAN**

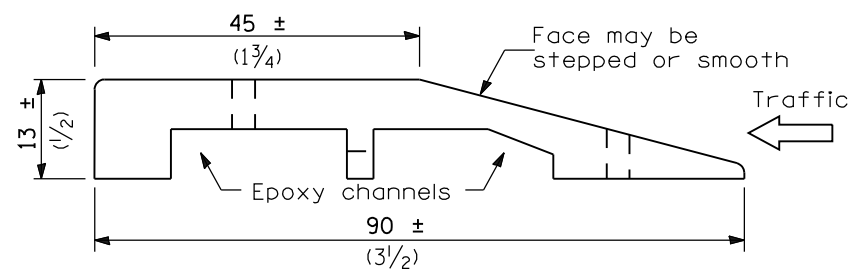

**SECTION A-A**

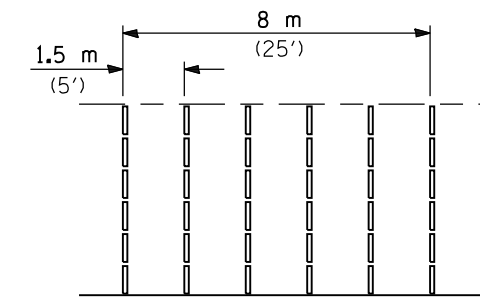
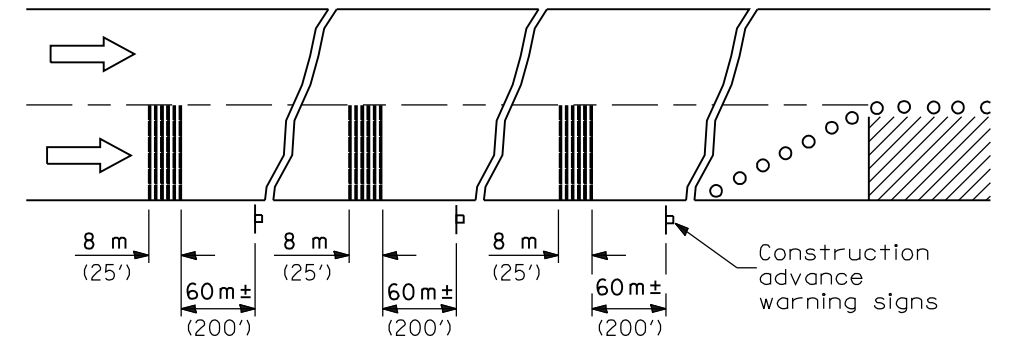

**TYPICAL INSTALLATION**

**TEMPORARY RUMBLE STRIPS**

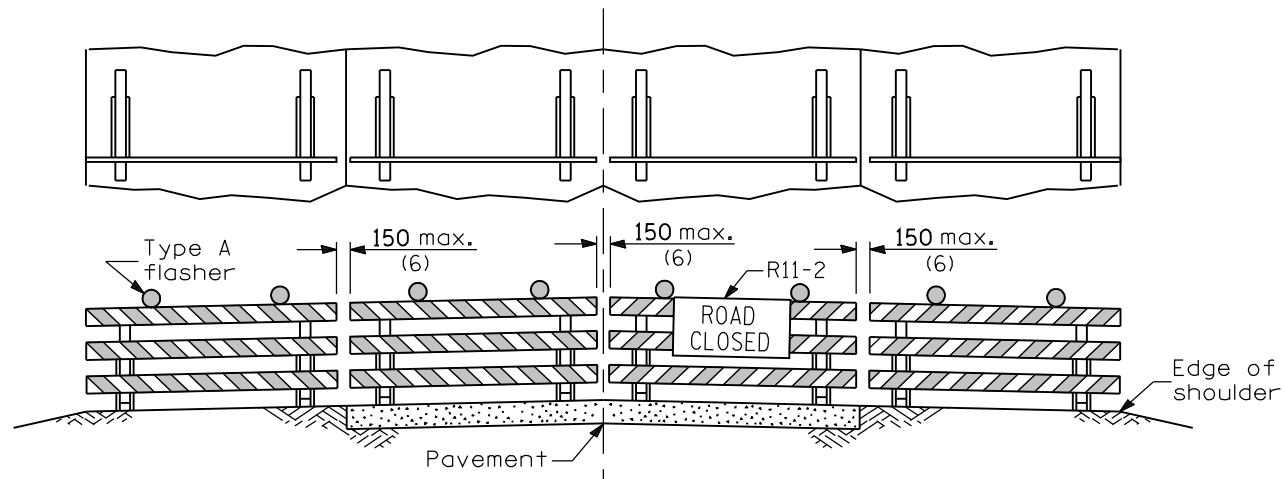

**ROAD CLOSED TO ALL TRAFFIC**

ReflectORIZED striping may be omitted on the back side of the barricades. If a Type III barricade with an attached sign panel which meets NCHRP 350 is not available, the sign may be mounted on an NCHRP 350 temporary sign support directly in front of the barricade.

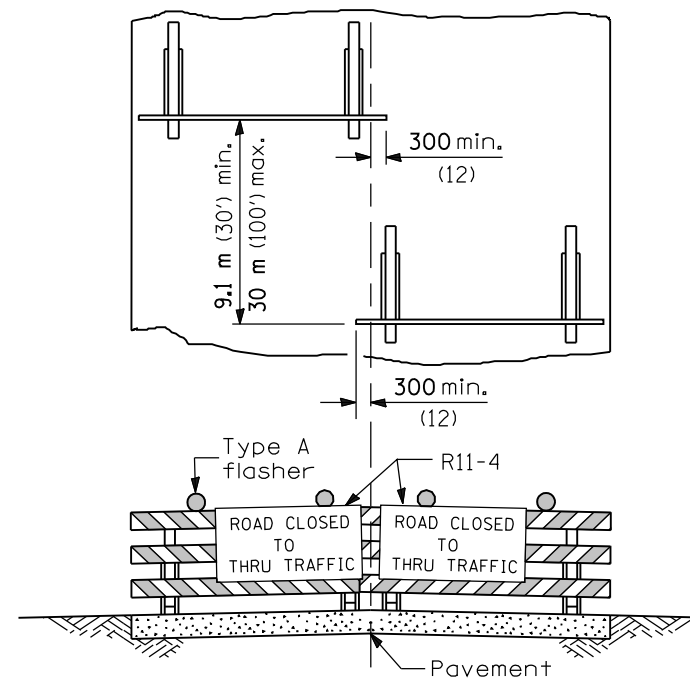

**ROAD CLOSED TO THRU TRAFFIC**

ReflectORIZED striping shall appear on both sides of the barricades. If a Type III barricade with an attached sign panel which meets NCHRP 350 is not available, the signs may be mounted on NCHRP 350 temporary sign supports directly in front of the barricade.

All dimensions are in millimeters (inches) unless otherwise shown.

**TYPICAL APPLICATIONS OF  
TYPE III BARRICADES CLOSING A ROAD**

Illinois Department of Transportation  
 APPROVED January 1, 2008  
 ENGINEER OF OPERATIONS  
 APPROVED January 1, 2008  
 ENGINEER OF DESIGN AND ENVIRONMENT  
 ISSUED 1-1-97

**TRAFFIC CONTROL  
DEVICES**

(Sheet 3 of 3)

**STANDARD 701901**