

LEGAL NOTICE - MUST RUN IN  
SOUTHTOWNSTAR  
THURSDAY FEBRUARY 9, 2012

LEGAL NOTICE

VILLAGE OF ORLAND PARK, ILLINOIS  
ADVERTISEMENT FOR BIDS

**STAINLESS STEEL POOL HANDRAILS**

The Village of Orland Park, Illinois will receive sealed bids until 11:00 A.M. on the 23rd day of February, 2012 at the Office of the Village Clerk, 14700 S. Ravinia Ave., Orland Park, Illinois 60462, for the purchase and installation of Stainless Steel Pool Handrails. All Bids received will be publicly opened and read aloud on said date and time at the Village Hall, 14700 Ravinia Avenue, Orland Park, Illinois, 60462, before the Village Manager or his designee.

The specifications are on file and available for inspection and copies will be available at the Office of the Village Clerk and online on the Village's website, [www.orland-park.il.us](http://www.orland-park.il.us).

A pre-bid meeting will be held on Thursday, February 16, 2012 at 9:00 A.M. at the Centennial Park Aquatic Center, 15600 West Avenue, Orland Park, Illinois.

No bid shall be withdrawn after the opening of the bid without the consent of the Village for a period of sixty (60) days after the scheduled time of opening and reading bids.

The President and Board of Trustees reserve the right to reject any and all bids or parts thereof and to waive any informalities, technicalities and irregularities in bidding and to disregard all non-conforming or conditional bids.

The successful bidder shall be required to comply with the provisions of all State of Illinois and federal laws as well as the State of Illinois Human Rights Act and the regulations of the Illinois Human Rights Commission.

By order of the President and Board of Trustees of the Village of Orland Park, Cook and Will Counties, Illinois.

PRESIDENT AND BOARD OF TRUSTEES  
VILLAGE OF ORLAND PARK, ILLINOIS

BY: DAVID P. MAHER  
VILLAGE CLERK



**VILLAGE OF ORLAND PARK, ILLINOIS**

**INVITATION TO BID**

**Stainless Steel Pool Handrails with Installation**

**ISSUED**

February 9, 2012

**PRE-BID MEETING**

February 16, 2012 at 9:00 AM  
Centennial Park Aquatic Center  
15600 West Ave

**BID OPENING**

February 23, 2012  
11:00 am

**VILLAGE OF ORLAND PARK, ILLINOIS**  
**Stainless Steel Pool Handrails with Installation**  
**INVITATION TO BID**

**TABLE OF CONTENTS**

**I. INSTRUCTIONS TO BIDDERS**

- Overview..... 2
- Bid Specifications ..... 4
- General Provisions ..... 5
- Bid Submission Requirements..... 8
- Evaluation of Bids/Bidders ..... 10
- Bid Submittal Checklist ..... 11

**II. REQUIRED BID SUBMISSION DOCUMENTS**

- Bidder Summary Sheet..... 13
- Business Organization ..... 14
- Certificate of Eligibility to Enter into Contracts ..... 15
- Equal Employment Opportunity ..... 16
- Certification of Compliance With the Illinois Prevailing Wage Act..... 18
- Contractor’s Certification Sexual Harassment, Tax & Substance Abuse . 19
- Apprenticeship and Training Program Certification..... 20
- References ..... 21
- Insurance Requirements..... 22

**III. EXHIBITS/ ADDITIONAL INFORMATION**

- Exhibit A Local Vendor Purchasing Policy ..... 24
- Exhibit B Sample Standard Form Contract ..... 25
- Exhibit C Detail Specifications ..... 29

**VILLAGE OF ORLAND PARK, ILLINOIS**  
**Stainless Steel Pool Handrails with Installation**  
**INVITATION TO BID**

**I. INSTRUCTIONS TO BIDDERS**

**OVERVIEW**

The Village of Orland Park requests Bids for the purchase and installation of stainless steel pool handrails ("Project") for Centennial Park Aquatic Center in the Village of Orland Park, Illinois ("Village"). See Specifications prepared by The Village of Orland Park Parks Department for details on the Project ("Specifications").

In order to be responsive, SEALED BIDS must be signed and received by the Village of Orland Park in the Office of the Village Clerk, 14700 South Ravinia Avenue, Orland Park, Illinois 60462, not later than 11:00 a.m., local prevailing time on Thursday February 23, 2012. All sealed bids must be submitted to the Village Clerk, located at the above stated address. All sealed bids submitted properly will be opened publicly and read aloud immediately following the stated submission time for the Project which described in detail consists of the following:

Purchase and installation of stainless steel pool handrails for Centennial Park Aquatic Center.

Oral, telephonic, facsimile or electronically transmitted bids shall not be considered.

A pre-bid meeting will be held on Thursday, February 16, 2012 at 9:00 A.M., at the Centennial Park Aquatic Center, 15600 West Ave, Orland Park, IL 60462.

No oral comments will be made to any Bidder as to the meaning of the Specifications or other contract documents. Requests for comments shall be made in writing. Contact Gary Couch by fax at (708) 403-6289, if you have any technical questions on this project. Inquiries received in writing within five (5) or more days prior to the bid opening will be given consideration and answers will be provided in writing to all potential bidders and will be available to the public. Bidders will not be relieved of obligations due to failure to examine or receive documents, visit the site or become familiar with conditions or facts of which the Bidder should have been aware and the Village will reject all claims related thereto.

Information (other than in the form of a written Addendum issued by the Village) from any officer, agent, or employee of the Village or any other person shall not affect the risks or obligations assumed by the bidder or relieve him from fulfilling any of the conditions and obligations set forth in the bid and other contract documents. Before the bids are opened, all modification or additions to the Specifications or General Provisions, or other bid documents will be made in the form of a written Addendum issued by the Village. The Village will send copies of any such Addendum not less than three (3) calendar days before bids are opened to those persons who have received bid packages and provided sufficient contact information. In the event of conflict with the original contract documents,

**VILLAGE OF ORLAND PARK, ILLINOIS**  
**Stainless Steel Pool Handrails with Installation**  
**INVITATION TO BID**

addenda shall govern all other contract documents to the extent specified. Subsequent addenda shall govern over prior addenda only to the extent specified.

**The bidder shall be required to acknowledge receipt of the formal Addendum by signing the Addendum and including it with the bid quotation.** Failure of a bidder to include a signed formal Addendum in its bid quotation shall deem its quotation non-responsive; provided, however, that the Village may waive this requirement in its best interest.

Any references in the Specifications to manufacturer's name, trade name, or catalog number (unless otherwise specified) is intended to be descriptive but not restrictive and only to indicate articles or materials that will be satisfactory. Bids on other makes and catalogs will be considered, provided each bidder clearly states on the face of their bid exactly what is proposed to be furnished. Unless so stated in the bid, it shall be understood that the bidder intends to furnish the item specified and does not propose to furnish an "equal." The Village hereby reserves the right to approve as an equal, or to reject as not being an equal any article the bidder proposes to furnish which contains minor or major variations from specification requirements, but which may comply substantially therewith.

**VILLAGE OF ORLAND PARK, ILLINOIS**  
**Stainless Steel Pool Handrails with Installation**  
**INVITATION TO BID**

**BID SPECIFICATIONS FOR:**

Purchase and installation of stainless steel pool handrails for Centennial Park Aquatic Center.

**SCOPE OF WORK:**

The Centennial Park Aquatic Center Lazy River has a sloped entry that requires a set of two (2) ADA accessible handrails to extend down the entire length (62') with a slope of 4.21% (rise 2.61 feet, length 62 linear feet).

The Centennial Park Aquatic Center Zero-Depth pool has one (1) set of pool stairs that needs a set of three (3) ADA accessible handrails.

Please see Exhibit C Detail Specifications in Section III for more information.

**SPECIAL CONDITIONS:**

All work must be completed by May 15, 2012.

**Bid Submission:**

Please provide a total proposed not-to-exceed fee on the Bidders Summary Sheet located in Section II.

**VILLAGE OF ORLAND PARK, ILLINOIS**  
**Stainless Steel Pool Handrails with Installation**  
**INVITATION TO BID**

**GENERAL PROVISIONS**

**Contract** – The successful bidder will be required to enter into a standard form contract with the Village of Orland Park within ten (10) business days of notice of bid award (hereinafter referred to as the “Contract”).

This contract will expire upon completion, inspection, acceptance and final payment for the work/goods/services performed whichever occurs first. Certain provisions of the Contract shall survive the expiration or termination of the Contract.

**Resident Inspector** – The Director of Parks or his designee reserves the right to make any inspections at any time.

**Period of Performance** - Actual work cannot begin until the Village issues a written Notice to Proceed to the Contractor. In order to receive said Notice, the Contractor shall submit to the Village for its approval all the necessary contracts and insurance. Village approval of the contracts and insurance shall be evidenced by its issuance of the signed contract by the Village and the Notice to Proceed. The Village reserves the right to terminate the relationship with the successful bidder if these documents are not submitted to and approved by the Village within ten (10) days of notice of bid award.

The work to be performed by the successful bidder shall be complete **on or before May 15, 2012**.

**Payments** – Payment terms shall be pursuant to the provisions of the Local Government Prompt Payment Act (50 ILCS 505/1 *et seq.*) after receipt by the Village of Contractor’s Dated Invoice, Contractor’s Sworn Statement, and Lien Waiver for the amount being requested. Invoices should include the following information:

- Name and address of contractor
- Purchase order number
- Dates of service
- Current invoice amount
- Invoices from subcontractors
- Lien Waivers from subcontractors

The Village may exercise its right to request photocopies of cancelled checks from the Contractor to his subcontractors, manufacturers, and suppliers, etc. Copies of these cancelled checks along with all applicable Lien Waivers shall accompany each pay request and shall be submitted for the month previous to the amount shown on the pay request.

Upon the Village's request, invoices for progress payments must include supporting documentation such as packing slips, subcontractor's invoice and material invoices.

**VILLAGE OF ORLAND PARK, ILLINOIS**  
**Stainless Steel Pool Handrails with Installation**  
**INVITATION TO BID**

**Changes in the Scope of Work** - Changes in the contractual scope of work shall be preceded by a duly executed Change Order itemizing any change in the Contract sum or terms and conditions and, if required by the Village, approved by the Village Board of Trustees prior to acceptance of the Change Order.

**Assignment** – Successful bidder shall not assign the work of this Project without the prior written approval of the Village.

**Compliance with Laws** – The bidder shall at all times observe and comply with all laws, ordinances and regulations of the federal, state, local and Village governments, which may in any manner affect the preparation of bids or the performance of the Contract.

Bidder hereby agrees that it will comply with all requirements of the Illinois Human Rights Act, 775 ILCS 5/1-101 et seq., including the provision dealing with sexual harassment and that if awarded the Contract will not engage in any prohibited form of discrimination in employment as defined in that Act and will require that its subcontractors agree to the same restrictions. The contractor shall maintain, and require that its subcontractors maintain, policies of equal employment opportunity which shall prohibit discrimination against any employee or applicant for employment on the basis of race, religion, color, sex, national origin, ancestry, citizenship status, age, marital status, physical or mental disability unrelated to the individual's ability to perform the essential functions of the job, association with a person with a disability, or unfavorable discharge from military service. Contractors and all subcontractors shall comply with all requirements of the Act and of the Rules of the Illinois Department of Human Rights with regard to posting information on employees' rights under the Act. Contractors and all subcontractors shall place appropriate statements identifying their companies as equal opportunity employers in all advertisements for workers to be employed in work to be performed.

Not less than the Prevailing Rate of Wages as found by the Village of Orland Park or the Department of Labor shall be paid to laborers, workmen, and mechanics performing work under the Contract. If awarded the Contract, contractor must comply with all provisions of the Illinois Prevailing Wage Act, including, but not limited to, providing certified payroll records to the Village Clerk. Contractor and subcontractors shall be required to comply with all applicable federal laws, state laws and regulations regarding minimum wages, limit on payment to minors, minimum fair wage standards for minors, payment of wage due employees, and health and safety of employees. Contractor and subcontractor are required to pay employees all rightful salaries, medical benefits, pension and social security benefits pursuant to applicable labor agreements and federal and state statutes and to further require withholdings and deposits therefore.

Any contractor doing work in the Village must obtain a Contractor's license from the Village of Orland's Building Department, as may be required by Village code.



**VILLAGE OF ORLAND PARK, ILLINOIS**  
**Stainless Steel Pool Handrails with Installation**  
**INVITATION TO BID**

**Guarantees and Warranties** - All guarantees and warranties required shall be furnished by the bidder if awarded the Contract and shall be delivered to the Finance Department before final payment on the Contract is issued. Information describing such guarantees and warranties shall be included as part of the bid.

The bidder shall also specify any guarantees or warranties which are available for purchase by the Village and shall transfer the same in writing upon completion of the work, along with a Bill of Sale as may be appropriate.

By submitting a bid, bidder expressly warrants that materials furnished under the contract will be of good quality and new unless otherwise expressly required or permitted by the contract documents, that the work will be free from defects for one (1) year from the issuance of the final payment by the Village and deficiencies shall be corrected by the contractor under its warranty immediately upon notification from the Village.

**Alternates** - Materials are specified. Alternate equipment and or material other than those outlined within this packet will need to be specified with a cut sheet within the contractor's bid. If for any reason and at the sole discretion of the Village of Orland Park any alternate equipment and or materials are deemed to be unacceptable the entire bid maybe disregarded.

**Indemnification** - The selected contractor shall indemnify and hold harmless the Village of Orland Park ("Village"), its trustees, officers, directors, agents, employees, representative and assigns, from lawsuits, actions, costs (including attorney's fees), claims or liability of any character, incurred due to the alleged negligence of the Contractor, brought because of any injuries or damages received or sustained by any person, persons or property on account of any act or omission, neglect or misconduct of said Contractor, its officers, agents and/or employees arising out of, or in performance of any of the provisions of the Contract Documents, including any claims or amounts recovered for any infringements of patent, trademark or copyright; or from any claims or amounts arising or recovered under the "Worker's Compensation Act: or any other law, ordinance, order or decree. In connection with any such claims, lawsuits, actions or liabilities, the Village, its trustees, officers, directors, agents, employees, representatives and their assigns shall have the right to defense counsel of their choice. The Contractor shall be solely liable for all costs of such defense and for all expenses, fees, judgments, settlements and all other costs arising out of such claims, lawsuits, actions or liabilities.

The Contractor shall not make any settlement or compromise of a lawsuit or claim, or fail to pursue any available avenue of appeal of any adverse judgment, without the approval of the Village and any other indemnified party. The Village or any other indemnified party, in its or their sole discretion, shall have the option of being represented by its or their own counsel. If this option is exercised, then the Contractor shall promptly reimburse the Village or other indemnified party, upon written demand, for any expenses, including but not limited to court costs, reasonable attorneys' and witnesses' fees and other expenses of litigation incurred by the Village or other indemnified party in connection therewith.

**VILLAGE OF ORLAND PARK, ILLINOIS**  
**Stainless Steel Pool Handrails with Installation**  
**INVITATION TO BID**

**BID SUBMISSION REQUIREMENTS**

**Bidder must submit three (3) complete, sealed, signed and attested copies of the bid, two (2) of which shall be complete bound copies and one (1) of which shall be a complete, identical, unbound copy of the bid, and shall have provided all requested information, and submitted all appropriate forms, certificates, affidavits and addendum acknowledgements in each copy in order to be considered responsive. All copies shall contain the forms with the original signatures (please include a photocopy of the bid bond in the unbound copy).**

Once submitted, no bid may be withdrawn without the Village's consent, but it may be superseded by a subsequent timely bid. Any bid received after the time and date specified for opening, or any postponement thereof, will not be considered. Bids shall be irrevocable for a period of sixty (60) calendar days after the Village opens them.

Each bidder is responsible for reading the bid documents and determining that the Specifications describe the work to be performed in sufficient detail. Failure of a bidder to do so shall not relieve the bidder of any obligation with respect to said bid. Bidders shall notify the Village of any inappropriate service, brand name, component, or equipment called for by the Village in the Specifications and shall note in its bid the adjustments made to accommodate such deficiencies in the Specifications. After bids have been opened, no bidder shall assert that there was a misunderstanding concerning the nature of the work to be done or the quantities and specifications of the materials/items to be delivered, and no such claim shall relieve a bidder from its obligation to perform. All bids must be made only on the forms provided by the Village and must be made in accordance with this Invitation to Bid and Specifications, (Project manual) all of which are on file and may be obtained for examination in the Clerk's Office at the above address and are made part of this notice as though fully set forth herein.

**Bidder Summary Sheet** – Section II includes the Bidder Summary Sheet that must be completed and submitted with the bid package.

**References** – Bidders shall provide the Village with the names and contact information of three (3) references for which they have performed similar work. The bidders grant Village permission to contact said references and ask questions regarding prior work performance. Village shall use the information gained from bidder's references to further evaluate the bidders.

**Insurance** – Contractor shall purchase and maintain, at all times during the performance of the work under this Contract, insurance coverage and endorsements, including Worker's Compensation, Automobile Liability, Comprehensive General Liability and Excess Liability, in the amounts set forth in the Village's Insurance Requirements attached in Section II. Bidders must sign and submit with the bid, the Insurance Requirements page, as recognition of the insurance coverage and amounts (hereinafter referred to as "coverage(s)") that will be required to be in place before the commencement of any work by the successful bidder. By signing this

**VILLAGE OF ORLAND PARK, ILLINOIS**  
**Stainless Steel Pool Handrails with Installation**  
**INVITATION TO BID**

form, the bidder is certifying that in the event the bidder does not already have the required insurance coverage in place, that the bidder has checked with their insurance carrier and verified that the coverage and endorsements requested will be able to be obtained by the bidder within ten (10) days after the date of the Notice of Award of the Contract. The bidder has the sole responsibility of verifying that the coverage and endorsements will be available for purchase and has made any and all inquiries necessary to satisfy this requirement and fully inform themselves in regards to any additional policy premiums the successful bidder may incur as a result of obtaining said required coverage's. The bidder also represents that they have taken the insurance requirements into account and at the bidders' sole discretion, has factored this into the bid prices submitted. The successful bidder is solely and entirely responsible for the payment of policy premiums and in no event will the Village of Orland Park be obligated to incur any additional expense, nor will the Village increase the amount of the Contract above the amount bid, as a result of any expense the successful bidder may incur to satisfy the obligations required herein.

**Please submit with the bid, a current policy Specimen Certificate of Insurance showing the insurance coverages the bidder currently has in force.**

Upon award of the contract, any insurance policies providing the coverages required of the Contractor shall be specifically endorsed to identify "*The Village of Orland Park, and their respective officers, trustees, directors, employees and agents as Additional Insureds on a primary/non-contributory basis with respect to all claims arising out of operations by or on behalf of the named insured.*" If the named insureds have other applicable insurance coverage, that coverage shall be deemed to be on an excess or contingent basis. The policies shall also contain a "Waiver of Subrogation in favor of the Additional Insureds in regards to General Liability and Workers Compensation coverage's." The certificate of insurance shall also state this information on its face and endorsements will be required to be submitted if awarded the contract.

**Bid Price** - The submitted bid price shall include all permits, insurance, goods/materials, plant facilities, work and expense necessary to perform the work in accordance with the Specifications included in this bid package. The submitted bid price shall not include any amount for sales or use taxes, or any other tax from which the Village is exempt.

The Specifications describe the standards of construction and are not intended to describe a particular manufacturer's product.

**VILLAGE OF ORLAND PARK, ILLINOIS**  
**Stainless Steel Pool Handrails with Installation**  
**INVITATION TO BID**

**EVALUATION OF BIDS/BIDDERS**

The Village reserves the right to accept any bid, any part or parts thereof, or to reject any and all bids.

The Village reserves the right to waive minor informalities or irregularities in the bids received, to accept any bid deemed advantageous to the Village, or to reject any and all bids submitted. Conditional bids, or those which take exception to the Contract documents without prior written approval from the Village, may be considered non-responsive and may be rejected.

The Village may make such investigations as it deems necessary to determine the ability of the bidder to perform the work in conformity with the Contract documents, and the bidder shall furnish to the Village all such information and data for this purpose as the Village may request.

The Contract shall be awarded to the lowest responsive, responsible bidder. In determining the lowest responsive and responsible bid, consideration will be given to several factors, including but not limited to price, financial responsibility of the bidder, completion date, responsiveness to the specifications, and the experience of the Village and other purchasers with the bidders.

Award of the contract is subject to Village of Orland Park Board approval. The Corporate Authority of the Village may elect to enforce its Local Vendor Purchasing Policy (see Section III Exhibit A – Local Vendor Purchasing Policy) when awarding the contract.

By submitting its bid, the bidder agrees to furnish, upon request from the Village, all information (including a list of subcontractors and suppliers and their prices) reasonably necessary for analysis. Furthermore, the Village may request that the bidder show, in detail, the kinds, quantities, and prices of direct material and direct labor used to develop prices/costs submitted in the bid. In addition, the Village reserves the right to request and receive information explaining the estimating process, including the judgmental factors and methods used to project from known data, and the contingencies used. The Village may require the bidder to show how it computes and applies indirect costs, and to show trend and budgetary data.

The Village may also conduct a pre-award facility survey of the bidder. This survey may include, but is not limited to, determining if the bidder has the experience, capability, necessary facilities and financial resources to complete the contract in a satisfactory manner within the required time.

The Village award will be made within sixty (60) calendar days after the date of the bid opening, or any mutually agreed extension thereof.

**VILLAGE OF ORLAND PARK, ILLINOIS**  
**Stainless Steel Pool Handrails with Installation**  
**INVITATION TO BID**

**BID SUBMITTAL CHECKLIST**

In order to be responsive, the bidder must submit all of the following items:

- Sealed Bid Envelope - **Addressed to the Village of Orland Park, Attn: Village Clerk's Office**, 14700 S. Ravinia Ave., Orland Park, IL 60462, and labeled: **–Stainless Steel Pool Handrails with Installation - Bid**, in the lower left hand corner.
- Bid - Bidder must submit **three (3) complete, sealed, signed and attested copies of the bid, two (2) of which shall be complete bound copies and one (1) of which shall be a complete, identical, unbound copy of the bid**, and shall have provided all requested information, and submitted all appropriate forms, certificates, affidavits and addendum acknowledgements in each copy in order to be considered responsive. All copies shall contain the forms with the original signatures (please include a photocopy of the bid bond in the unbound copy). Note: only need to include those required documents listed in Section II in the bid submission.
- All forms completed from Section II:
  - Bidder Summary Sheet
  - Business Organization
  - Certificate of Eligibility to Enter into Public Contracts
  - Equal Employment Opportunity
  - Certification of Compliance With the Illinois Prevailing Wage Act
  - Contractor's Certification Sexual Harassment, Tax & Substance Abuse
  - Apprenticeship and Training Program Certification
  - References
  - Insurance Requirements

## **II – REQUIRED BID SUBMISSION DOCUMENTS**

**BIDDER SUMMARY SHEET**

Stainless Steel Pool Handrails  
Project Name

IN WITNESS WHEREOF, the parties hereto have executed this Bid as of date shown below.

Firm Name: \_\_\_\_\_

Address: \_\_\_\_\_

City, State, Zip Code: \_\_\_\_\_

Contact Person: \_\_\_\_\_

FEIN #: \_\_\_\_\_

Phone: (\_\_\_\_) \_\_\_\_\_ Fax: (\_\_\_\_) \_\_\_\_\_

E-mail Address: \_\_\_\_\_

**RECEIPT OF ADDENDA:** The receipt of the following addenda is hereby acknowledged:

Addendum No. \_\_\_\_\_, Dated \_\_\_\_\_

Addendum No. \_\_\_\_\_, Dated \_\_\_\_\_

**Handrails for Lazy River** \$ \_\_\_\_\_

**Handrails for Zero-Depth Pool** \$ \_\_\_\_\_

**TOTAL BID PRICE** \$ \_\_\_\_\_

Signature of Authorized Signee: \_\_\_\_\_

Title: \_\_\_\_\_ Date: \_\_\_\_\_

**BUSINESS ORGANIZATION:**

\_\_\_\_\_ Sole Proprietor: An individual whose signature is affixed to this bid.

\_\_\_\_\_ Partnership: Attach sheet and state full names, titles and address of all responsible principals and/or partners. Provide percent of ownership and a copy of partnership agreement.

\_\_\_\_\_ Corporation: State of incorporation: \_\_\_\_\_  
Provide a disclosure of all officers and principals by name and business address, date of incorporation and indicate if the corporation is authorized to do business in Illinois.

In submitting this bid, it is understood that the Village of Orland Park reserves the right to reject any or all bids, to accept an alternate bid, and to waive any informalities in any bid.

In compliance with your Invitation to Bid, and subject to all conditions thereof, the undersigned offers and agrees, if this bid is accepted, to furnish the services as outlined.

\_\_\_\_\_ (Corporate Seal)  
Business Name

\_\_\_\_\_ Signature \_\_\_\_\_ Print or type name

\_\_\_\_\_ Title \_\_\_\_\_ Date



**CERTIFICATION OF ELIGIBILITY  
TO ENTER INTO PUBLIC CONTRACTS**

**IMPORTANT: THIS CERTIFICATION MUST BE EXECUTED.**

I, \_\_\_\_\_, being first duly sworn certify  
and say that I am \_\_\_\_\_  
(insert "sole owner," "partner," "president," or other proper title)

of \_\_\_\_\_, the Prime Contractor submitting this proposal, and that the Prime Contractor is not barred from contracting with any unit of state or local government as a result of a violation of either Section 33E-3, or 33E-4 of the Illinois Criminal Code, or of any similar offense of "bid-rigging" or "bid-rotating" of any state or of the United States.

\_\_\_\_\_  
Signature of Person Making Certification

Subscribed and Sworn To  
Before Me This \_\_\_\_\_ Day  
of \_\_\_\_\_, 20\_\_.

\_\_\_\_\_  
Notary Public

## EQUAL EMPLOYMENT OPPORTUNITY

**Section I.** This EQUAL EMPLOYMENT OPPORTUNITY CLAUSE is required by the Illinois Human Rights Act and the Rules and Regulations of the Illinois Department of Human Rights published at 44 Illinois Administrative Code Section 750, et seq.

**Section II.** In the event of the Contractor's noncompliance with any provision of this Equal Employment Opportunity Clause, the Illinois Human Right Act, or the Rules and Regulations for Public Contracts of the Department of Human Rights (hereinafter referred to as the Department) the Contractor may be declared non-responsible and therefore ineligible for future contracts or subcontracts with the State of Illinois or any of its political subdivisions or municipal corporations, and this agreement may be canceled or avoided in whole or in part, and such other sanctions or penalties may be imposed or remedies involved as provided by statute or regulation.

During the performance of this Agreement, the Contractor agrees:

**A.** That it will not discriminate against any employee or applicant for employment because of race, color, religion, sex, national origin or ancestry; and further that it will examine all job classifications to determine if minority persons or women are underutilized and will take appropriate affirmative action to rectify any such underutilization.

**B.** That, if it hires additional employees in order to perform this Agreement, or any portion hereof, it will determine the availability (in accordance with the Department's Rules and Regulations for Public Contracts) of minorities and women in the area(s) from which it may reasonably recruit and it will hire for each job classification for which employees are hired in such a way that minorities and women are not underutilized.

**C.** That, in all solicitations or advertisements for employees placed by it or on its behalf, it will state that all applicants will be afforded equal opportunity without discrimination because of race, color, religion, sex, marital status, national origin or ancestry, age, or physical or mental handicap unrelated to ability, or an unfavorable discharge from military service.

**D.** That it will send to each labor organization or representative of workers with which it has or is bound by a collective bargaining or other agreement or understanding, a notice advising such labor organization or representative of the Contractor's obligations under the Illinois Human Rights Act and Department's Rules and Regulations for Public Contract.

**E.** That it will submit reports as required by the Department's Rules and Regulations for Public Contracts, furnish all relevant information as may from time to time be requested by the Department or the contracting agency, and in all respects comply with the Illinois Human Rights Act and Department's Rules and Regulations for Public Contracts.

**F.** That it will permit access to all relevant books, records, accounts and work sites by personnel of the contracting agency and Department for purposes of investigation to

ascertain compliance with the Illinois Human Rights Act and Department's Rules and Regulations for Public Contracts.

**G.** That it will include verbatim or by reference the provisions of this Equal Employment Opportunity Clause in every subcontract it awards under which any portion of this Agreement obligations are undertaken or assumed, so that such provisions will be binding upon such subcontractor. In the same manner as the other provisions of this Agreement, the Contractor will be liable for compliance with applicable provisions of this clause by such subcontractors; and further it will promptly notify the contracting agency and the Department in the event any subcontractor fails or refuses to comply therewith. In addition, the Contractor will not utilize any subcontractor declared by the Illinois Human Rights Department to be ineligible for contracts or subcontracts with the State of Illinois or any of its political subdivisions or municipal corporations.

**Section III.** For the purposes of subsection G of Section II, "subcontract" means any agreement, arrangement or understanding, written or otherwise, between the Contractor and any person under which any portion of the Contractor's obligations under one or more public contracts is performed, undertaken or assumed; the term "subcontract", however, shall not include any agreement, arrangement or understanding in which the parties stand in the relationship of an employer and an employee, or between a Contractor or other organization and its customers.

**ACKNOWLEDGED AND AGREED TO:**

NAME: \_\_\_\_\_

SIGNATURE: \_\_\_\_\_

WITNESS: \_\_\_\_\_

DATE: \_\_\_\_\_

**CERTIFICATION OF COMPLIANCE WITH THE  
ILLINOIS PREVAILING WAGE ACT  
(820 ILCS 130/0.01, et seq.)**

It is hereby stipulated and certified to the Village of Orland Park, that the undersigned Contractor shall pay not less than the prevailing hourly rate of wages, the generally prevailing rate of hourly wages for legal holiday and overtime work, and the prevailing hourly rate for welfare and other benefits as determined by the Illinois Department of Labor and as set forth in the schedule of prevailing wages for this contract to all laborers, workers and mechanics performing work under this contract. The undersigned Contractor further stipulates and certifies that he/she/it has maintained a satisfactory record of Prevailing Wage Act compliance with no significant Prevailing Wage Act violations for the past three (3) years. In accordance with Public Act 94-0515, the Contractor will submit to the Village certified payroll records (to include for every worker employed on the project the name, address, telephone number, social security number, job classification, hourly wages paid in each pay period, number of hours worked each day and starting and ending time of work each day) on a monthly basis, along with a statement affirming that such records are true and accurate, that the wages paid to each worker are not less than the required prevailing rate and that the Contractor is aware that knowingly filing false records is a Class B Misdemeanor.

**Contractor:**

**By:** \_\_\_\_\_  
(Authorized Officer)

Subscribed and Sworn To  
Before Me This \_\_\_\_\_ Day  
of \_\_\_\_\_, 20\_\_.

\_\_\_\_\_  
Notary Public

**VILLAGE OF ORLAND PARK  
CONTRACTOR'S CERTIFICATION  
SEXUAL HARASSMENT, TAX & SUBSTANCE ABUSE**

\_\_\_\_\_, having been first duly sworn deposes and states as follows:  
(Officer or Owner of Company)

\_\_\_\_\_, having submitted a proposal for:  
(Name of Company)

\_\_\_\_\_  
(PROJECT)

to the Village of Orland Park, Illinois, hereby certifies that the undersigned Contractor:

1. has a written sexual harassment policy in place in full compliance with 775 ILCS 5/2-105(A)(4).
2. is not delinquent in the payment of any tax administered by the Illinois Department of Revenue, or if:
  - a. it is contesting its liability for the tax or the amount of tax in accordance with procedures established by the approved Revenue Act; or
  - b. it has entered into an agreement with the Department of Revenue for payment of all taxes due and is currently in compliance with that agreement.
3. is in full compliance with the Federal Highway Administration Rules on Controlled Substances and Alcohol Use and Testing, 49 CFR Parts 40 and 382 and that \_\_\_\_\_ is/are currently participating  
(Name of employee/driver or "all employee drivers")  
in a drug and alcohol testing program pursuant to the aforementioned rules.

\_\_\_ 4A. has in place a written program which meets or exceeds the program requirements of the Substance Abuse Prevention on Public Works Projects Act (Public Act 95-0635), and has provided a written copy thereof to the Village of Orland Park; or

\_\_\_ 4B. has in place a collective bargaining agreement which deals with the subject matter of the Substance Abuse Prevention on Public Works Projects Act (Public Act 95-0635).

(Check either 4A or 4B, depending upon which certification is correct.)

By: \_\_\_\_\_  
Officer or Owner of Company named above

Subscribed and Sworn To  
Before Me This \_\_\_\_\_ Day  
of \_\_\_\_\_, 20\_\_.

\_\_\_\_\_  
Notary Public

**APPRENTICESHIP AND TRAINING PROGRAM CERTIFICATION**

I, \_\_\_\_\_, having been first duly sworn depose and state as follows:

I, \_\_\_\_\_, am the duly authorized agent for \_\_\_\_\_, which has submitted a bid to the Village of Orland Park for

\_\_\_\_\_ and I hereby certify  
(Name of Project)

that \_\_\_\_\_  
(Name of Company)

participates in apprenticeship and training programs approved and registered with the United States Department of Labor Bureau of Apprenticeship and Training.

By: \_\_\_\_\_

Title: \_\_\_\_\_

Subscribed and Sworn To  
Before Me This \_\_\_\_\_ Day  
of \_\_\_\_\_, 20\_\_.

\_\_\_\_\_  
Notary Public

**REFERENCES**

**(Please type)**

ORGANIZATION \_\_\_\_\_

ADDRESS \_\_\_\_\_

CITY, STATE, ZIP \_\_\_\_\_

PHONE NUMBER \_\_\_\_\_

CONTACT PERSON \_\_\_\_\_

DATE OF PROJECT \_\_\_\_\_

ORGANIZATION \_\_\_\_\_

ADDRESS \_\_\_\_\_

CITY, STATE, ZIP \_\_\_\_\_

PHONE NUMBER \_\_\_\_\_

CONTACT PERSON \_\_\_\_\_

DATE OF PROJECT \_\_\_\_\_

ORGANIZATION \_\_\_\_\_

ADDRESS \_\_\_\_\_

CITY, STATE, ZIP \_\_\_\_\_

PHONE NUMBER \_\_\_\_\_

CONTACT PERSON \_\_\_\_\_

DATE OF PROJECT \_\_\_\_\_

Bidder's Name: \_\_\_\_\_

Signature & Date: \_\_\_\_\_

## INSURANCE REQUIREMENTS

*Please submit a policy Specimen Certificate of Insurance showing bidder's current coverage's*

### WORKERS COMPENSATION & EMPLOYER LIABILITY

\$500,000 – Each Accident

\$500,000 – Policy Limit

\$500,000 – Each Employee

Waiver of Subrogation in favor of the Village of Orland Park

### AUTOMOBILE LIABILITY

\$1,000,000 – Combined Single Limit

Additional Insured Endorsement in favor of the Village of Orland Park

### GENERAL LIABILITY (Occurrence basis)

\$1,000,000 – Each Occurrence

\$2,000,000 – General Aggregate Limit

\$1,000,000 – Personal & Advertising Injury

\$2,000,000 – Products/Completed Operations Aggregate

Additional Insured Endorsement & Waiver of Subrogation in favor of the Village of Orland Park

### EXCESS LIABILITY (Umbrella-Follow Form Policy)

\$2,000,000 – Each Occurrence

\$2,000,000 – Aggregate

**EXCESS MUST COVER:** General Liability, Automobile Liability, Workers Compensation

Any insurance policies providing the coverages required of the Contractor, shall be specifically endorsed to identify “The Village of Orland Park, and their respective officers, trustees, directors, employees and agents as Additional Insureds on a primary/non-contributory basis with respect to all claims arising out of operations by or on behalf of the named insured.” If the named insureds have other applicable insurance coverage, that coverage shall be deemed to be on an excess or contingent basis. The policies shall also contain a Waiver of Subrogation in favor of the Additional Insureds in regards to General Liability and Workers Compensation coverage's. The certificate of insurance shall also state this information on its face. Any insurance company providing coverage must hold an A VII rating according to Best's Key Rating Guide. Permitting the contractor, or any subcontractor, to proceed with any work prior to our receipt of the foregoing certificate and endorsement however, shall not be a waiver of the contractor's obligation to provide all of the above insurance.

The bidder agrees that if they are the selected contractor, within ten days after the date of notice of the award of the contract and prior to the commencement of any work, you will furnish evidence of Insurance coverage providing for at minimum the coverages and limits described above directly to the Village of Orland Park, Denise Domalewski, Contract Administrator, 14700 S. Ravinia Avenue, Orland Park, IL 60462. Failure to provide this evidence in the time frame specified and prior to beginning of work may result in the termination of the Village's relationship with the selected bidder and the bid will be awarded to the next lowest bidder or result in creation of a new bid.

ACCEPTED & AGREED THIS \_\_\_\_ DAY OF \_\_\_\_\_, 20\_\_

\_\_\_\_\_  
Signature

\_\_\_\_\_  
Authorized to execute agreements for:

\_\_\_\_\_  
Printed Name & Title

\_\_\_\_\_  
Name of Company



### **III – ADDITIONAL INFORMATION (EXHIBITS)**

## EXHIBIT A

### VILLAGE OF ORLAND PARK LOCAL VENDOR PURCHASING POLICY

The Village of Orland Park believes it is important to provide local vendors with opportunities to provide goods and services to the Village of Orland Park. This belief is based upon the fact that the active uses of commercial properties in the Village benefits the community through stabilization of the property tax base, the creation of local sales tax and the provision of employment opportunities for citizens of the community and surrounding region.

In an effort to promote the aforementioned benefits, the Village of Orland Park wishes to provide local vendors with preferential treatment when competing for contracts with the Village. A local vendor is defined as a business that has an actual business location within the corporate boundaries of Orland Park and is licensed by the Village. The Village will not award a contract to a local vendor when the difference between the local vendors bid and the otherwise lowest responsive and responsible bid exceeds the applicable percentage indicated below. As such, when considering contracts, the Village reserves the right to forego the lowest responsive and responsible bid in favor of a local vendor under the following circumstances:

<u>Contract Value</u>	<u>Range (up to a maximum of)</u>
\$0 - \$250,000	2.00%
\$250,000 - 1,000,000	1.50%
\$1,000,000 - 2,000,000	1.00%
Greater than \$2,000,000	Not Applicable

Under no circumstance will any contract be awarded to a local vendor when the local vendor's bid exceeds the lowest responsive and responsible bid by \$20,000 or more.

This Policy shall ONLY apply if formal notice of the aforementioned criteria is provided as part of the bid specifications. In addition, it should be noted that the Village of Orland Park shall not be obligated to forego the low bidder in favor of the local vendor under any circumstances. However, this Policy simply provides the Village with the option of doing so when applicable. Furthermore, this Policy shall not apply in any situation where any portion of the contract amount is being paid with funds other than Village monies. Specifically, this Policy shall not apply in any situation where the Village has received a grant or otherwise received a source of funds other than its own funds.

**EXHIBIT B**  
**\* \* SAMPLE \* \***  
**VILLAGE OF ORLAND PARK**  
**(Contract for Small Construction or Installation Project)**

This Contract is made this \_\_\_\_ day of \_\_\_\_\_, 20\_\_ by and between the Village of Orland Park (hereinafter referred to as the “VILLAGE”) and \_\_\_\_\_ (hereinafter referred to as the “CONTRACTOR”).

**WITNESSETH**

In consideration of the promises and covenants made herein by the VILLAGE and the CONTRACTOR (hereinafter referred to collectively as the “PARTIES”), the PARTIES agree as follows:

**SECTION 1: THE CONTRACT DOCUMENTS:** This Contract shall include the following documents (hereinafter referred to as the “CONTRACT DOCUMENTS”) however this Contract takes precedence and controls over any contrary provision in any of the CONTRACT DOCUMENTS. The Contract, including the CONTRACT DOCUMENTS, expresses the entire agreement between the PARTIES and where it modifies, adds to or deletes provisions in other CONTRACT DOCUMENTS, the Contract’s provisions shall prevail. Provisions in the CONTRACT DOCUMENTS unmodified by this Contract shall be in full force and effect in their unaltered condition.

- The Contract
- The Terms and General Conditions pertaining to the Contract
- The VILLAGE’S Project Manual for the Work as described in Section 2 hereunder
  - o The Invitation to Bid
  - o The Instructions to the Bidders
- The Bid Proposal as it is responsive to the VILLAGE’s bid requirements
- All Certifications required by the VILLAGE
- Certificates of Insurance
- ~~Performance and Payment Bonds required by the VILLAGE~~

**SECTION 2: SCOPE OF THE WORK AND PAYMENT:** The CONTRACTOR agrees to provide labor, equipment and materials necessary to perform the following:

---

---

---

---

(hereinafter referred to as the “WORK”) as described in the VILLAGE’S Project Manual (Bid Documents) and the VILLAGE agrees to pay the CONTRACTOR pursuant to the provisions of the Local Government Prompt Payment Act (50 ILCS 505/1 *et seq.*) the following amounts for the WORK:

Unit Prices (if any):

_____	_____
_____	_____
_____	_____

Alternates chosen:

\_\_\_\_\_

\_\_\_\_\_

TOTAL: \_\_\_\_\_ No/100 (\$ \_\_\_\_\_) Dollars  
 (hereinafter referred to as the "CONTRACT SUM.") The CONTRACT SUM shall not be increased without the express written consent of the VILLAGE.

**SECTION 3: ASSIGNMENT:** CONTRACTOR shall not assign the duties and obligations involved in the performance of the WORK except to the list of Subcontractors approved by the Village, which approval shall not be unreasonably withheld.

**SECTION 4: TERM OF THE CONTRACT:** The CONTRACTOR shall commence the WORK of this Contract upon receipt of a Notice to Proceed and shall complete performance of the WORK of this Contract by \_\_\_\_\_, (hereinafter referred to as the "CONTRACT TIME.") Failure to meet the CONTRACT TIME shall be considered an occasion of default under the CONTRACT DOCUMENTS. The CONTRACT TIME shall not be increased without the express written consent of the VILLAGE. Final payment shall be made by the VILLAGE upon inspection of the WORK, completion of any punch list items and after receipt of final release and waiver of liens in accordance with the requirements of the CONTRACT DOCUMENTS. This Contract may be terminated by the VILLAGE for convenience or by either of the PARTIES for default in the performance of the duties of the PARTIES as described in the CONTRACT DOCUMENTS upon thirty (30) day's written notice provided as required herein.

**SECTION 5: INDEMNIFICATION AND INSURANCE:** The CONTRACTOR shall indemnify and hold harmless the VILLAGE, its trustees, officers, directors, agents, employees and representatives and assigns, from lawsuits, actions, costs (including attorneys' fees), claims or liability of any character, incurred due to the alleged negligence of the CONTRACTOR, brought because of any injuries or damages received or sustained by any person, persons or property on account of any act or omission, neglect or misconduct of said CONTRACTOR, its officers, agents and/or employees arising out of, or in performance of any of the provisions of the CONTRACT DOCUMENTS, including any claims or amounts recovered for any infringements of patent, trademark or copyright; or from any claims or amounts arising or recovered under the "Worker's Compensation Act" or any other law, ordinance, order or decree. In connection with any such claims, lawsuits, actions or liabilities, the VILLAGE, its trustees, officers, directors, agents, employees, representatives and their assigns shall have the right to defense counsel of their choice. The CONTRACTOR shall be solely liable for all costs of such defense and for all expenses, fees, judgments, settlements and all other costs arising out of such claims, lawsuits, actions or liabilities.

The Contractor shall not make any settlement or compromise of a lawsuit or claim, or fail to pursue any available avenue of appeal of any adverse judgment, without the approval of the Village and any other indemnified party. The Village or any other indemnified party, in its or their sole discretion, shall have the option of being represented by its or their own counsel. If this option is exercised, then the Contractor shall promptly reimburse the Village or other indemnified party, upon written demand, for any expenses, including but not limited to court costs, reasonable attorneys' and witnesses' fees and other expenses of litigation incurred by the Village or other indemnified party in connection therewith.

The indemnification obligation under this paragraph shall not be limited in any way by any limitations on the amount or type of damages, compensation or benefits payable by or for the benefit of Subcontractor or any indemnities under any Worker's Compensation Act, Occupational Disease Act, Disability Benefits Act, or any other employee benefits act. The Subcontractor further agrees to waive any and all liability limitations based upon the Worker's Compensation Act court interpretations or otherwise.

Execution of this Contract by the VILLAGE is contingent upon receipt of Insurance Certificates provided by the CONTRACTOR in compliance with the CONTRACT DOCUMENTS.

**SECTION 6: COMPLIANCE WITH LAWS:** CONTRACTOR agrees to comply with all federal, state and local laws, ordinances, statutes, rules and regulations including but not limited to all applicable provisions of the Illinois Human Rights Act (775 ILCS 5/1-101 *et seq.*) and the Illinois Prevailing Wage Act (820 ILCS 130/1 *et seq.*)

**SECTION 7: FREEDOM OF INFORMATION ACT COMPLIANCE:** The Illinois Freedom of Information Act (FOIA) has been amended and effective January 1, 2010. This amendment adds a new provision to Section 7 of the Act which applies to public records in the possession of a party with whom the Village of Orland Park has contracted. The Village of Orland Park will have only a very short period of time from receipt of a FOIA request to comply with the request, and there is a significant amount of work required to process a request including collating and reviewing the information.

The undersigned acknowledges the requirements of FOIA and agrees to comply with all requests made by the Village of Orland Park for public records (as that term is defined by Section 2(c) of FOIA) in the undersigned's possession and to provide the requested public records to the Village of Orland Park within two (2) business days of the request being made by the Village of Orland Park. The undersigned agrees to indemnify and hold harmless the Village of Orland Park from all claims, costs, penalty, losses and injuries (including but not limited to, attorney's fees, other professional fees, court costs and/or arbitration or other dispute resolution costs) arising out of or relating to its failure to provide the public records to the Village of Orland Park under this agreement.

**SECTION 8: NOTICE:** Where notice is required by the CONTRACT DOCUMENTS, it shall be considered received if it is 1) delivered in person, 2) sent by registered United States mail, return receipt requested, 3) delivered by messenger or mail service with a signed receipt, 4) sent by facsimile with an acknowledgment of receipt, or 4) by e-mail with an acknowledgment of receipt only if the PARTIES agree separately to use e-mail for providing notice. Notice shall be sent to the following:

To the VILLAGE:  
Contract Administrator  
Village of Orland Park  
14700 South Ravinia Avenue  
Orland Park, Illinois 60462  
Telephone:  
Facsimile:  
e-mail:

To the CONTRACTOR:  
  
  
  
Telephone:  
Facsimile:  
e-mail:

or to such other persons or to such other addresses as may be provided by one party to the other party under the requirements of this Section.

**SECTION 9: LAW AND VENUE:** The law of the State of Illinois shall apply to this Agreement and venue for legal disputes shall be Cook County, Illinois.

**SECTION 10: MODIFICATION:** This Contract may be modified only by a written amendment signed by both PARTIES.

**SECTION 11: COUNTERPARTS:** This Contract may be executed in two (2) or more counterparts, each of which taken together, shall constitute one and the same instrument.

This Contract shall become effective on the date first shown herein and upon execution by duly authorized agents of the PARTIES.

FOR: THE VILLAGE

FOR: THE CONTRACTOR

By: \_\_\_\_\_

By: \_\_\_\_\_

Print name: \_\_\_\_\_

Print name: \_\_\_\_\_

Its: Village Manager

Its: \_\_\_\_\_

Date: \_\_\_\_\_

Date: \_\_\_\_\_

## EXHIBIT C DETAIL SPECIFICATIONS

### **Lazy River Sloped Entry Handrails:**

The Orland Park Aquatic Center Lazy River has a sloped entry that needs a set of two (2) ADA accessible handrails to extend down the entire length (62') with a slope of 4.21% (rise 2.61 feet, length 62 linear feet).

The handrails for the lazy river sloped entry shall comply with ADA accessibility requirements and shall have the following features:

- The lazy river handrails will be anchored or lag bolted to surface. The bolts (stainless steel) or anchors (stainless steel) must be covered with flange cover to avoid sharp corners. All measurements must be verified on site.

### ***Top and Bottom Extension at Ramps:***

Ramp handrails shall extend horizontally above the landing for 12 inches (305 mm) minimum beyond the top and bottom of ramp runs. Extensions shall return to a handrail post as seen in Figure 1.

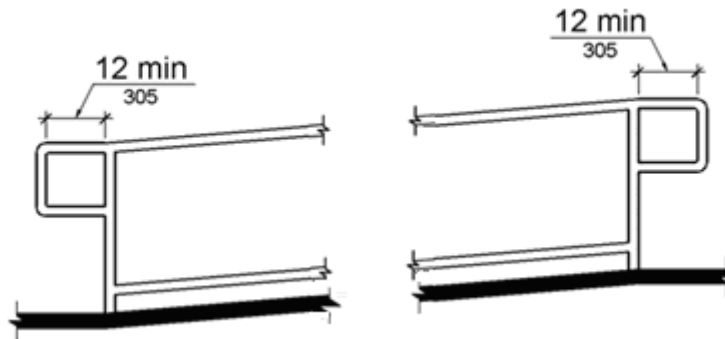

**Figure 1 - Top and Bottom Handrail Extension at Ramps**

### ***Barrier:***

A barrier shall be provided that prevents the passage of a 4 inch (100 mm) diameter sphere, where, any portion of the sphere is within 4 inches (100 mm) of the finish floor or ground surface as seen in Figure 2.

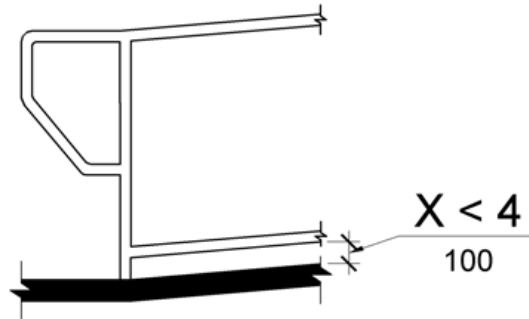

**Figure 2  
Barrier Edge Protection**

***Continuity:***

Handrails shall be continuous within the full length of each stair flight or ramp run.

***Height:***

Top of gripping surfaces of handrails shall be 34 inches (865 mm) above the ramp surface as seen in Figure 3. Handrails shall be at a consistent height above the ramp surface.

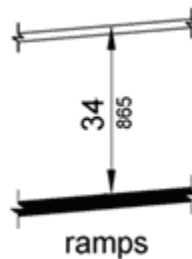

**Figure 3 - Handrail Height**

***Gripping Surface:***

Handrail gripping surfaces shall be continuous along their length and shall not be obstructed along their tops or sides. The bottoms of handrail gripping surfaces shall not be obstructed for more than 20 percent of their length.

***Circular Cross Section:***

Handrail gripping surfaces with a circular cross section shall have an outside diameter of 1¼ inches (32 mm) minimum and 2 inches (51 mm) maximum.



**Surfaces:**

Handrail gripping surfaces and any surfaces adjacent to them shall be free of sharp or abrasive elements and shall have rounded edges.

**Fittings:**

Handrails shall not rotate within their fittings.

**Zero-Depth Pool Stairs Handrails:**

The Orland Park Aquatic Center Zero-Depth pool has one (1) set of pool stairs that needs a set of three (3) ADA accessible handrails.

The handrails for the pool stairs must comply with ADA accessibility requirements and shall have the following features:

- The pool stairs handrails shall be core drilled and grouted into stairs. All measurements must be verified on site.

**Top Extension at Stairs:**

At the top of a stair flight, handrails shall extend horizontally above the landing for 12 inches (305 mm) minimum beginning directly above the first riser nosing. Extensions shall return to a handrail post as seen in Figure 4.

**Bottom Extension at Stairs:**

At the bottom of a stair flight, handrails shall not extend past the pool edge and shall return to the bottom stair surface as seen in Figure 4.

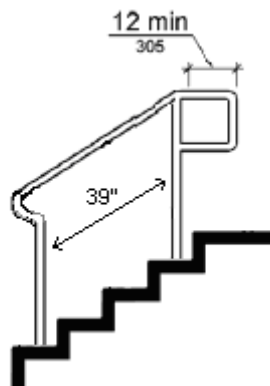

**Figure 4  
Handrail Extensions at Stairs**

**Continuity:**

Handrails shall be continuous within the full length of each stair flight or ramp run.

**Height:**

Top of gripping surfaces of handrails shall be 34 inches (865 mm) vertically above walking surfaces, stair nosings, and ramp surfaces. Handrails shall be at a consistent height above walking surfaces, stair nosings, and ramp surfaces as seen in Figure 5.

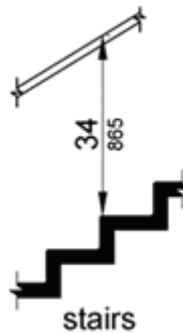

**Figure 5 - Handrail Height**

**Gripping Surface:**

Handrail gripping surfaces shall be continuous along their length and shall not be obstructed along their tops or sides. The bottoms of handrail gripping surfaces shall not be obstructed for more than 20 percent of their length.

**Circular Cross Section:**

Handrail gripping surfaces with a circular cross section shall have an outside diameter of 1¼ inches (32 mm) minimum and 2 inches (51 mm) maximum.

**Surfaces:**

Handrail gripping surfaces and any surfaces adjacent to them shall be free of sharp or abrasive *elements* and shall have rounded edges.

***Fittings:***

Handrails shall not rotate within their fittings.

***Pool Stairs Handrails:***

The width between handrails shall be 20 inches (510 mm) minimum and 24 inches (610 mm) maximum. The bottom handrail extensions required by ADA regulation 505.10.3 shall not be required on pool stairs.